

CITY OF MERCER ISLAND

DEVELOPMENT SERVICES GROUP

9611 SE 36TH STREET | MERCER ISLAND, WA 98040

PHONE: 206.275.7605 | www.mercergov.org

Inspection Requests: Online: www.MyBuildingPermits.com VM: 206.275.7730



SECTION A: SMALL PROJECT STORMWATER SITE PLAN/REPORT

Narrative and Plan Submittal

Instructions: This is a template for a simplified Stormwater Report. This form or an equivalent must accompany your Building Permit Application if the answer is "Yes" to each statement below. If "No" is the answer to one or more of the statements below, a full Drainage Report is required and the project does not qualify for use of the Small Project Stormwater Site Plan/Report template.

Select "yes" or "no" for each statement below. Answer "yes" if the statement accurately describes your project.

Yes	No	Statement
		This project disturbs less than 1 acre and is not part of a larger common plan of development.
		This project converts less than 3/4 acre to lawn or landscape areas.
		This project will create, add, or replace (in any combination) 2,000 square feet or greater, but less than 5,000 square feet, of new plus replaced hard surface OR will have a land disturbing activity of 7,000 square feet or greater OR will result in a net increase of impervious surface of 500 square feet or greater.
		This project will not adversely impact a wetland, stream, water of the state, or change a natural drainage course.

Basic Project Information

Project Name: _____

Site Address: _____

Total Lot Size: _____

Total Proposed Area to be Disturbed (including stockpile area): _____ sq ft

Total Volume of Proposed Cut and Fill: _____ sq ft

Total Proposed New Hard Surface Area: _____ sq ft

Total Proposed Replaced Hard Surface Area: _____ sq ft

Total Proposed Converted Pervious Surface Area
(Native vegetation to lawn or landscape): _____ sq ft

Net Increase in Impervious Surface: _____ sq ft



CITY OF MERCER ISLAND

SECTION A: SMALL PROJECT STORMWATER SITE PLAN/REPORT

Minimum Requirement #1 : Preparation of Stormwater Site Plan

Written Project Description:

Calculate new or replaced areas by surface type:

Lawn or Landscape Areas: _____ sq ft	Roof Area: _____ sq ft
Other Hard Surface Areas:	
Driveway: _____ sq ft Patio: _____ sq ft Sidewalk: _____ sq ft	
Parking Lot: _____ sq ft Other: _____ sq ft	

Attach Drainage Plan

Drainage Plan shall include the following:

- Scaled drawing with slopes, lot lines, any public-right-of-way and any easements, location of each on-site stormwater management BMP selected above and the areas served by them, buildings, roads, parking lots, driveways, landscape features, and areas of disturbed soils to be amended.
- The scaled drawing must be suitable to serve as a recordable document that will be attached to the property deed for each lot that includes on-site BMPs. Document submittal must follow the “Standard Formatting Requirements for Recording Documents” per King County: www.kingcounty.gov/depts/records-licensing/recorders-office/recording-documents.aspx
- Identify design details and maintenance instructions for each on-site BMP, and attach them to this Small Project Stormwater Site Plan/Report.

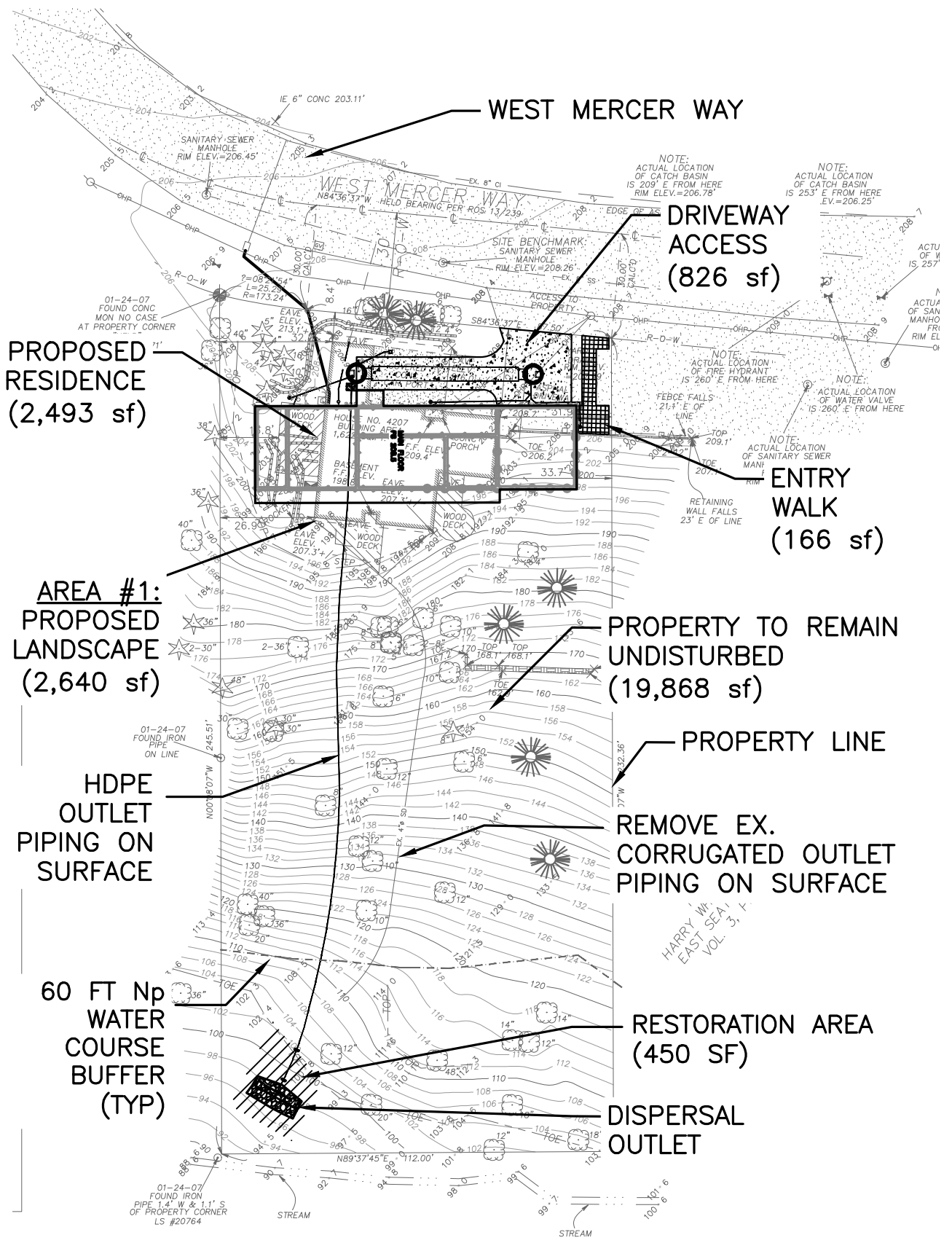

PROPOSED RESIDENCE
(2,493 sf)

DRIVEWAY ACCESS
(826 sf)

ENTRY WALK
(166 sf)

AREA #1: PROPOSED LANDSCAPE
(2,640 sf)

PROPERTY TO REMAIN UNDISTURBED
(19,868 sf)

HDPE OUTLET PIPING ON SURFACE

PROPERTY LINE
REMOVE EX. CORRUGATED OUTLET PIPING ON SURFACE

60 FT Np WATER COURSE BUFFER (TYP)

RESTORATION AREA
(450 SF)

DISPERSAL OUTLET

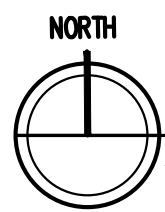

DRAINAGE PLAN
4207 West Mercer Way

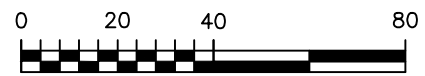

SCALE: 1" = 40'

CALL 48 HOURS BEFORE YOU DIG
1-800-424-5555
OR CALL 8-1-1

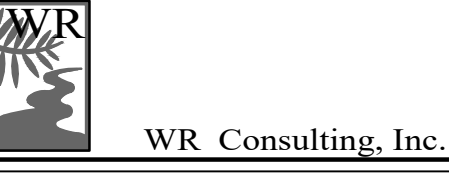
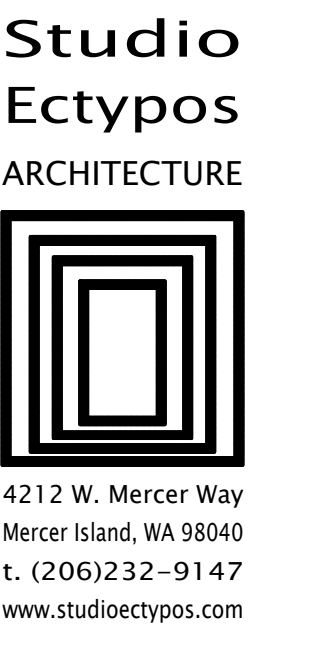

Civil Engineer:
WR Consulting, Inc.
3611 45th Ave W.
Seattle, WA 98199
P: 206.285.1593

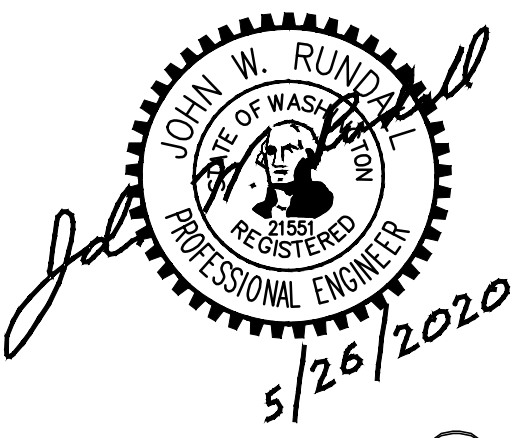

VANEY / SHINDE
New Residence
4207 West Mercer Way
Mercer Island, WA 98040

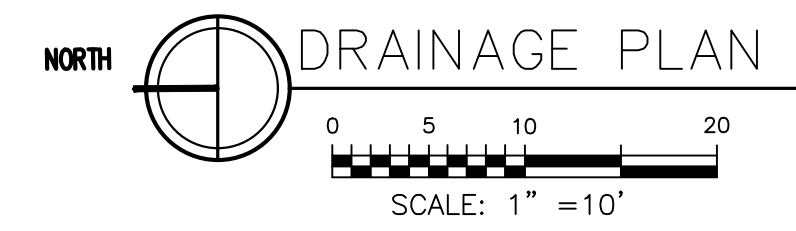
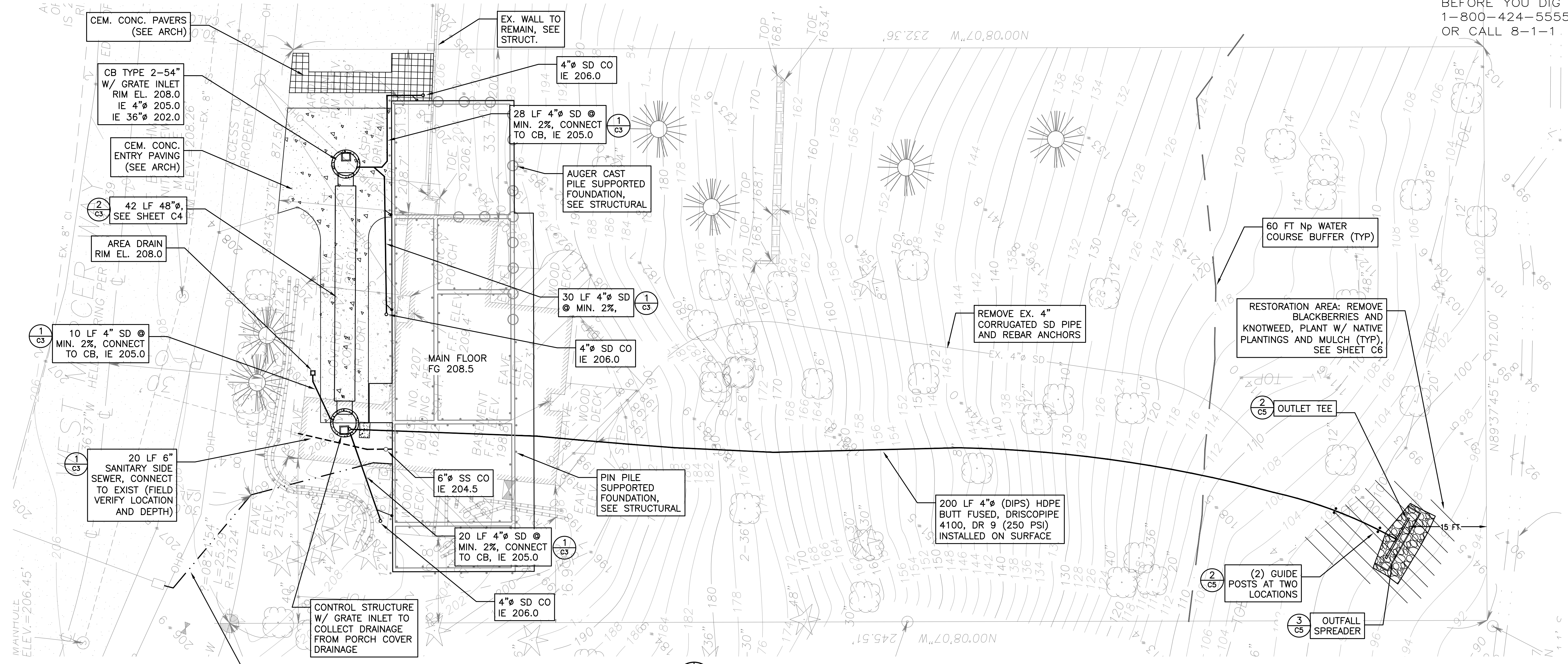

DETENTION TANK CONSTRUCTION SEQUENCING NOTES:

1. DETENTION TANK AND ASSOCIATED STRUCTURES SHALL BE INSTALLED ONLY AFTER PIN PILE AND AUGER CAST FOUNDATIONS ARE COMPLETE.
2. EXCAVATION FOR DETENTION TANK SHALL BE A SINGLE VERTICAL WALL TRENCH WITH TEMPORARY SHORING AND SAFETY SYSTEMS AS REQUIRED.
3. THE DETENTION TANK SHALL BE LOWERED INTO PLACE AND BACKFILLED AS INDICATED. EXCESS SPOILS SHALL BE REMOVED FROM THE SITE IMMEDIATELY.
4. HEAVY EQUIPMENT OR MACHINERY SHALL NOT ACCESS THE STEEP SLOPE BELOW THE HOUSE. THE STORM DRAIN PIPING AND OUTFALL WORK BELOW THE HOUSE SHALL BE BY HAND WORK AND PORTABLE TOOLS, NOT HEAVY EQUIPMENT.

LEGEND

- AREA DRAIN
- CATCH BASIN, TYPE 2-54"
- CLEAN OUT
- DOWNSPOUT CONNECTION
- - - FOUNDATION DRAIN
- FOUNDATION DRAIN CLEANOUT
- PROPANE
- - - SANITARY SIDE SEWER
- STORM DRAIN
- - - WATER SERVICE

CONSTRUCTION NOTES:

1. FURNISH AND INSTALL ALL TRANSITION COUPLINGS (FERNCO REDUCERS AND COUPLINGS) AS NEEDED FOR CONNECTIONS TO BLDG UTILITIES
2. INVERT ELEVATIONS ARE APPROXIMATE. ADJUST INVERT ELEVATIONS AS NEEDED TO COORDINATE WITH BLDG UTILITIES AND EXISTING GRADES.
3. SEE ARCHITECTURE PLANS FOR BUILDING AND SITE FURNISHINGS DETAILS.

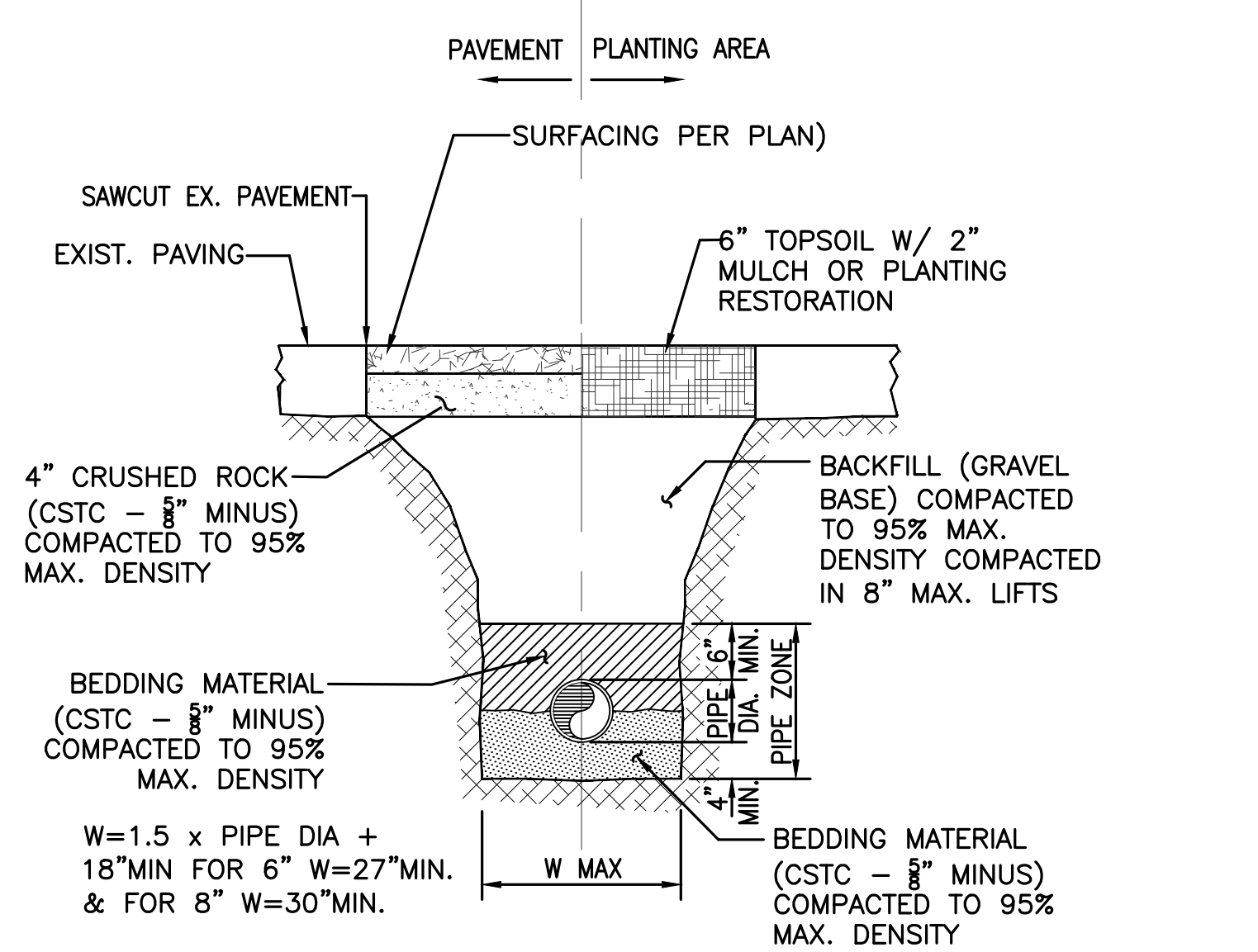

1 UTILITY TRENCH DETAIL
C3 NTS

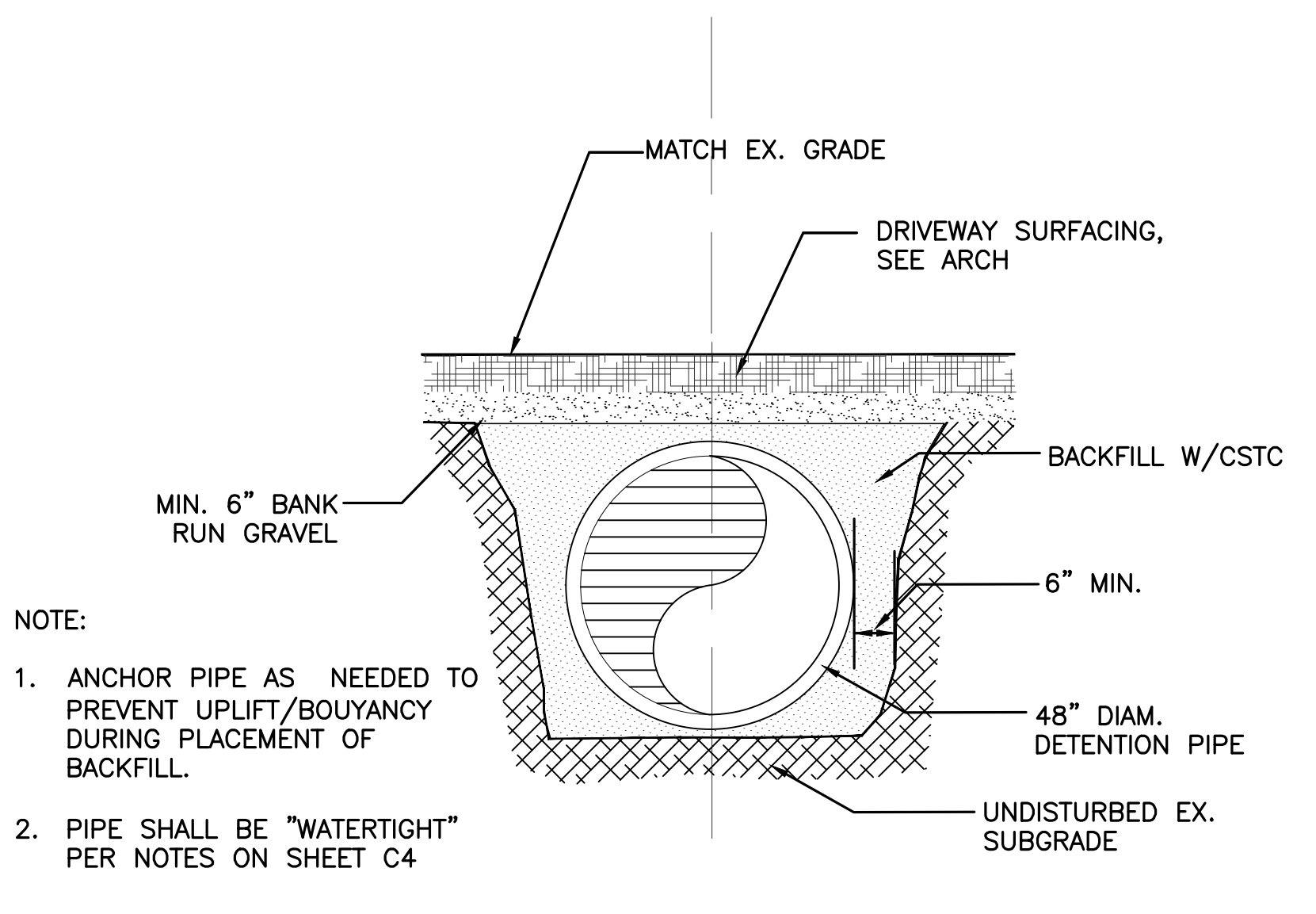

2 DETENTION PIPE DETAIL
C3 NTS

- NOTE:
1. ANCHOR PIPE AS NEEDED TO PREVENT UPLIFT/BOUYANCY DURING PLACEMENT OF BACKFILL.
 2. PIPE SHALL BE "WATERTIGHT" PER NOTES ON SHEET C4

Date: 5/21/20 Permit Set

Scale: 1" = 10'
Sheet: 3 of 6

DRAINAGE PLAN
C3

NOTE: SEE ADDITIONAL DETENTION PIPE DETAILS SHEET C4

**Table V-4.5.2(3) Maintenance Standards - Closed Detention Systems
(Tanks/Vaults)**

Maintenance Component	Defect	Conditions When Maintenance is Needed	Results Expected When Maintenance is Performed
Storage Area	Plugged Air Vents	One-half of the cross section of a vent is blocked at any point or the vent is damaged.	Vents open and functioning.
	Debris and Sediment	Accumulated sediment depth exceeds 10% of the diameter of the storage area for 1/2 length of storage vault or any point depth exceeds 15% of diameter. (Example: 72-inch storage tank would require cleaning when sediment reaches depth of 7 inches for more than 1/2 length of tank.)	All sediment and debris removed from storage area.
	Joints Between Tank/Pipe Section	Any openings or voids allowing material to be transported into facility. (Will require engineering analysis to determine structural stability).	All joint between tank/pipe sections are sealed.
	Tank Pipe Bent Out of Shape	Any part of tank/pipe is bent out of shape more than 10% of its design shape. (Review required by engineer to determine structural stability).	Tank/pipe repaired or replaced to design.
	Vault Structure Includes Cracks in Wall, Bottom, Damage to Frame and/or Top Slab	Cracks wider than 1/2-inch and any evidence of soil particles entering the structure through the cracks, or maintenance/inspection personnel determines that the vault is not structurally sound. Cracks wider than 1/2-inch at the joint of any inlet/outlet pipe or any evidence of soil particles entering the vault through the walls.	Vault replaced or repaired to design specifications and is structurally sound. No cracks more than 1/4-inch wide at the joint of the inlet/outlet pipe.
Manhole	Cover Not in Place	Cover is missing or only partially in place. Any open manhole requires maintenance.	Manhole is closed.

**Table V-4.5.2(3) Maintenance Standards - Closed Detention Systems
(Tanks/Vaults) (continued)**

Maintenance Component	Defect	Conditions When Maintenance is Needed	Results Expected When Maintenance is Performed
	Locking Mechanism Not Working	Mechanism cannot be opened by one maintenance person with proper tools. Bolts into frame have less than 1/2 inch of thread (may not apply to self-locking lids).	Mechanism opens with proper tools.
	Cover Difficult to Remove	One maintenance person cannot remove lid after applying normal lifting pressure. Intent is to keep cover from sealing off access to maintenance.	Cover can be removed and reinstalled by one maintenance person.
	Ladder Rungs Unsafe	Ladder is unsafe due to missing rungs, misalignment, not securely attached to structure wall, rust, or cracks.	Ladder meets design standards. Allows maintenance person safe access.
Catch Basins	See "Catch Basins" (No. 5)	See "Catch Basins" (No. 5).	See "Catch Basins" (No. 5).

Table V-4.5.2(4) Maintenance Standards - Control Structure/Flow Restrictor

Maintenance Component	Defect	Condition When Maintenance is Needed	Results Expected When Maintenance is Performed
General	Trash and Debris (Includes Sediment)	Material exceeds 25% of sump depth or 1 foot below orifice plate.	Control structure orifice is not blocked. All trash and debris removed.
	Structural Damage	Structure is not securely attached to manhole wall. Structure is not in upright position (allow up to 10% from plumb). Connections to outlet pipe	Structure securely attached to wall and outlet pipe. Structure in correct position. Connections to outlet pipe are water tight; structure repaired or replaced and works as

Table V-4.5.2(4) Maintenance Standards - Control Structure/Flow Restrictor (continued)

Maintenance Component	Defect	Condition When Maintenance is Needed	Results Expected When Maintenance is Performed
		are not watertight and show signs of rust. Any holes - other than designed holes - in the structure.	designed. Structure has no holes other than designed holes.
Cleanout Gate	Damaged or Missing	Cleanout gate is not watertight or is missing. Gate cannot be moved up and down by one maintenance person. Chain/rod leading to gate is missing or damaged. Gate is rusted over 50% of its surface area.	Gate is watertight and works as designed. Gate moves up and down easily and is watertight. Chain is in place and works as designed. Gate is repaired or replaced to meet design standards.
Orifice Plate	Damaged or Missing	Control device is not working properly due to missing, out of place, or bent orifice plate.	Plate is in place and works as designed.
	Obstructions	Any trash, debris, sediment, or vegetation blocking the plate.	Plate is free of all obstructions and works as designed.
Overflow Pipe	Obstructions	Any trash or debris blocking (or having the potential of blocking) the overflow pipe.	Pipe is free of all obstructions and works as designed.
Manhole	See "Closed Detention Systems" (No. 3).	See "Closed Detention Systems" (No. 3).	See "Closed Detention Systems" (No. 3).
Catch Basin	See "Catch Basins" (No. 5).	See "Catch Basins" (No. 5).	See "Catch Basins" (No. 5).

Table V-4.5.2(5) Maintenance Standards - Catch Basins

Maintenance Component	Defect	Conditions When Maintenance is Needed	Results Expected When Maintenance is performed
General	Trash & Debris	<p>Trash or debris which is located immediately in front of the catch basin opening or is blocking inletting capacity of the basin by more than 10%.</p> <p>Trash or debris (in the basin) that exceeds 60 percent of the sump depth as measured from the bottom of basin to invert of the lowest pipe into or out of the basin, but in no case less than a minimum of six inches clearance from the debris surface to the invert of the lowest pipe.</p> <p>Trash or debris in any inlet or outlet pipe blocking more than 1/3 of its height.</p> <p>Dead animals or vegetation that could generate odors that could cause complaints or dangerous gases (e.g., methane).</p>	<p>No Trash or debris located immediately in front of catch basin or on grate opening.</p> <p>No trash or debris in the catch basin.</p> <p>Inlet and outlet pipes free of trash or debris.</p> <p>No dead animals or vegetation present within the catch basin.</p>
	Sediment	<p>Sediment (in the basin) that exceeds 60 percent of the sump depth as measured from the bottom of basin to invert of the lowest pipe into or out of the basin, but in no case less than a minimum of 6 inches clearance from the sediment surface to the invert of the lowest pipe.</p>	<p>No sediment in the catch basin</p>
	Structure Damage to Frame and/or Top Slab	<p>Top slab has holes larger than 2 square inches or cracks wider than 1/4 inch. (Intent is to make sure no material is running into basin).</p>	<p>Top slab is free of holes and cracks.</p> <p>Frame is sit-</p>

Table V-4.5.2(5) Maintenance Standards - Catch Basins (continued)

Maintenance Component	Defect	Conditions When Maintenance is Needed	Results Expected When Maintenance is performed
		Frame not sitting flush on top slab, i.e., separation of more than 3/4 inch of the frame from the top slab. Frame not securely attached	ting flush on the riser rings or top slab and firmly attached.
	Fractures or Cracks in Basin Walls/ Bottom	Maintenance person judges that structure is unsound. Grout fillet has separated or cracked wider than 1/2 inch and longer than 1 foot at the joint of any inlet/outlet pipe or any evidence of soil particles entering catch basin through cracks.	Basin replaced or repaired to design standards. Pipe is regouted and secure at basin wall.
	Settlement/ Misalignment	If failure of basin has created a safety, function, or design problem.	Basin replaced or repaired to design standards.
	Vegetation	Vegetation growing across and blocking more than 10% of the basin opening. Vegetation growing in inlet/outlet pipe joints that is more than six inches tall and less than six inches apart.	No vegetation blocking opening to basin. No vegetation or root growth present.
	Contamination and Pollution	See "Detention Ponds" (No. 1).	No pollution present.
Catch Basin Cover	Cover Not in Place	Cover is missing or only partially in place. Any open catch basin requires maintenance.	Catch basin cover is closed
	Locking Mechanism Not	Mechanism cannot be opened by one maintenance person with proper tools. Bolts into	Mechanism opens with

Table V-4.5.2(5) Maintenance Standards - Catch Basins (continued)

Maintenance Component	Defect	Conditions When Maintenance is Needed	Results Expected When Maintenance is performed
	Working	frame have less than 1/2 inch of thread.	proper tools.
	Cover Difficult to Remove	One maintenance person cannot remove lid after applying normal lifting pressure. (Intent is keep cover from sealing off access to maintenance.)	Cover can be removed by one maintenance person.
Ladder	Ladder Rungs Unsafe	Ladder is unsafe due to missing rungs, not securely attached to basin wall, misalignment, rust, cracks, or sharp edges.	Ladder meets design standards and allows maintenance person safe access.
Metal Grates (If Applicable)	Grate opening Unsafe	Grate with opening wider than 7/8 inch.	Grate opening meets design standards.
	Trash and Debris	Trash and debris that is blocking more than 20% of grate surface inletting capacity.	Grate free of trash and debris.
	Damaged or Missing.	Grate missing or broken member(s) of the grate.	Grate is in place and meets design standards.

Table V-4.5.2(7) Maintenance Standards - Energy Dissipaters

Maintenance Components	Defect	Conditions When Maintenance is Needed	Results Expected When Maintenance is Performed
External:			
Rock Pad	Missing or Moved Rock	Only one layer of rock exists above native soil in area five square feet or larger, or any exposure of native soil.	Rock pad replaced to design standards.
	Erosion	Soil erosion in or adjacent to rock pad.	Rock pad replaced to design standards.
Dispersion Trench	Pipe Plugged with Sediment	Accumulated sediment that exceeds 20% of the design depth.	Pipe cleaned/flushed so that it matches design.
	Not Discharging Water Properly	Visual evidence of water discharging at concentrated points along trench (normal condition is a "sheet flow" of water along trench). Intent is to prevent erosion damage.	Trench redesigned or rebuilt to standards.
	Perforations Plugged.	Over 1/2 of perforations in pipe are plugged with debris and sediment.	Perforated pipe cleaned or replaced.
	Water Flows Out Top of "Distributor" Catch Basin.	Maintenance person observes or receives credible report of water flowing out during any storm less than the design storm or its causing or appears likely to cause damage.	Facility rebuilt or redesigned to standards.
	Receiving Area Over-Saturated	Water in receiving area is causing or has potential of causing landslide problems.	No danger of landslides.
Internal:			
Manhole/Chamber	Worn or Damaged Post, Baffles, Side of Chamber	Structure dissipating flow deteriorates to 1/2 of original size or any concentrated worn spot exceeding one square foot which would make structure unsound.	Structure replaced to design standards.
	Other Defects	See "Catch Basins" (No. 5).	See "Catch Basins" (No. 5).



CITY OF MERCER ISLAND

SECTION A: SMALL PROJECT STORMWATER SITE PLAN/REPORT

Minimum Requirement #2 : Construction Stormwater Pollution Prevention

- Complete Section B of this submittal package: Construction Stormwater Pollution Prevention Plan Narrative (SWPPP)
- Attach construction SWPPP

Minimum Requirement #3 : Source Control of Pollution

This section contains practices and procedures to reduce the release of pollutants. Provide a description of all known, available and reasonable source control BMPs that will be, or are anticipated to be, used at this location to prevent stormwater from coming into contact with pollutants. Additional BMPs are found in Volume IV of the 2014 Stormwater Management Manual for Western Washington (SWMMWW).

Check the BMPs you will use:

- BMP S411 for Landscaping and Lawn/ Vegetation Management
Operational practices for sites with landscaping
- BMP S421 for Parking and Storage of Vehicles.
Public and commercial parking lots can be sources of suspended solids, metals, or toxic hydrocarbons such oils and greases.
- BMP S433 for Pools, Spas, Hot Tubs, Fountains
Discharge from pools, hot tubs, and fountains can degrade ambient water quality. Routine maintenance activities generate a variety of wastes. Direct disposal of these waters to drainage system and waters of the state are not permitted without prior treatment and approval.
- Other BMPs found in Volume IV of SWMMWW applicable to project:

- No source control BMPs are applicable for this project.



CITY OF MERCER ISLAND

SECTION A: SMALL PROJECT STORMWATER SITE PLAN/REPORT

Minimum Requirement #4 : Preservation of Natural Drainage Systems

Natural drainage patterns shall be maintained and discharges from the project site shall occur at the natural location, to the maximum extent practicable. All outfalls require energy dissipation.

Choose the option below that best describes your project:

This site has existing drainage systems or outfalls. These items are shown on the Drainage Plan. Include the following items on the Drainage Plan:

- Pipe invert elevations, slopes, cover, and material
- Locations, grades, and direction of flow in ditches and swales, culverts, and pipes

Describe how these systems will be preserved:

This site does not have any existing drainage systems or outfalls.

Additional Comments:



CITY OF MERCER ISLAND

SECTION A: SMALL PROJECT STORMWATER SITE PLAN/REPORT

Minimum Requirement #5 : On-site Stormwater Management

All projects meeting the thresholds for this Small Project Stormwater Report shall employ on-site stormwater management BMPs (See Small Project Stormwater Requirements Tip Sheet) to infiltrate, disperse, and retain stormwater runoff on-site to the extent feasible without causing flooding or erosion impacts.

List #1

For each category select the *first* feasible item on the list below. Document your justification for each infeasible BMP in Section C of this submittal package.

Check one option for each category below:



Lawn and Landscape Areas

- My project does not have *Lawn or Landscape* areas
- Post-construction soil quality and depth
- Post-construction soil quality and depth is infeasible (see Section C of this submittal package)



Roofs

- My project does not have *Roof* areas
- 1. Full dispersion or downspout full infiltration
- 2. Rain garden or bioretention
- 3. Downspout dispersion system
- 4. Perforated stub-out connections
- 5. On-site detention system or fee-in-lieu of on-site detention authorized by the City Engineer (applicable if options #1-4 are infeasible and drainage from the site will be discharged to a storm or surface water system that includes a watercourse or there is a capacity constraint in the system)
- 6. No Roof BMP (applicable if options #1-4 are infeasible and on-site detention is not required)

Measured Infiltration Rate: _____ in/ hr

If #5 or #6 is selected, briefly describe why no Roof BMP is feasible (include detailed information in Section C of this submittal package):



CITY OF MERCER ISLAND

SECTION A: SMALL PROJECT STORMWATER SITE PLAN/REPORT

Minimum Requirement #5 : On-site Stormwater Management (cont.)



Other Hard Surfaces (such as driveway, sidewalk, parking lot, patio, etc.)

- My project does not have *Other Hard Surface* areas
- 1. Full dispersion
- 2. Permeable pavement, rain gardens, or bioretention
- 3. Sheet flow dispersion or concentrated flow dispersion
- 4. On-site detention system or fee-in-lieu of on-site detention authorized by the City Engineer (applicable if options #1-3 are infeasible and drainage from the site will be discharged to a storm or surface water system that includes a watercourse or there is a capacity constraint in the system)
- 5. No Other Hard Surface BMP (applicable if options #1-3 are infeasible and on-site detention is not required)

Measured Infiltration Rate: _____ in/ hr

If #4 or #5 is selected, briefly describe why no Other Hard Surface BMP is feasible (include detailed information in Section C of this submittal package):

Flow Control Exempt List

Proceed with this list if your project discharges directly to Lake Washington or if findings from a downstream analysis confirm that the downstream system is free of capacity constraints for a minimum of ¼ mile and a maximum of 1 mile.

For flow control exempt discharges, the BMPs listed below for Roofs and Other Hard Surfaces do not need to be evaluated in priority order. You can select any BMP from the lists provided below and do not need to document infeasibility in Section C of this submittal package.

Check one option for each category below:



Lawn and Landscape Areas

- My project does not have *Lawn or Landscape* areas
- Post-construction soil quality and depth



CITY OF MERCER ISLAND

SECTION A: SMALL PROJECT STORMWATER SITE PLAN/REPORT

Minimum Requirement #5 : On-site Stormwater Management (cont.)



Roofs

- My project does not have *Roof* areas
- Downspout full infiltration
- Downspout dispersion system
- Perforated stub-out connections
- Each item above is infeasible

If “Each item above is infeasible” is selected, briefly describe why no Roof BMP is feasible:



Other Hard Surfaces (such as driveway, sidewalk, parking lot, patio, etc.)

- My project does not have *Other Hard Surface* areas
- Sheet flow dispersion
- Concentrated flow dispersion
- Each item above is infeasible

If “Each item above is infeasible” is selected, briefly describe why no Other Hard Surface BMP is feasible:



CITY OF MERCER ISLAND

SECTION B: SMALL PROJECT CONSTRUCTION SWPPP NARRATIVE

Instructions

This is a template for a simplified Construction Stormwater Pollution Prevention Plan (“Construction SWPPP”). If “No” is the answer to one or more of the statements on the first page of Section A of this submittal package, then a full Construction SWPPP is required and the project does not qualify for the use of the Small Project Construction SWPPP Narrative template. If the project is less than the thresholds on the first page of Section A of this submittal package, then Minimum Requirement #2 still applies, but this section (Section B) or a full construction SWPPP is not required. You should include your Construction SWPPP in your contract with your builder. A copy of the Construction SWPPP must be located at the construction site or within reasonable access to the site for construction and inspection personnel at all times.

General Information on the Existing Site and Project

Describe the following in the Project Narrative box below (attach additional pages if necessary):

- Nature and purpose of the construction project
- Existing topography, vegetation, and drainage, and building structures
- Adjacent areas, including streams, lakes, wetlands, residential areas, and roads that might be affected by the construction project
- How upstream drainage areas may affect the site
- Downstream drainage leading from the site to the receiving body of water
- Areas on or adjacent to the site that are classified as critical areas
- Critical areas that receive runoff from the site up to one-quarter mile away
- Special requirements and provisions for working near or within critical areas
- Areas on the site that have potential erosion problems

Project Narrative:



CITY OF MERCER ISLAND

SECTION B: SMALL PROJECT CONSTRUCTION SWPPP NARRATIVE

Construction SWPPP Drawings

Refer to the general Drawing Requirements in Stormwater Management Manual for Western Washington (SWMMWW) Volume I, Chapter 3.

Vicinity Map

Provide a map with enough detail to identify the location of the construction site, adjacent roads, and receiving waters.

Site Map

Include the following (where applicable):

- | | |
|--|---|
| <input type="checkbox"/> Legal description of the property boundaries or an illustration of property lines (including distances) on the drawings. | <input type="checkbox"/> Final and interim grade contours as appropriate, drainage basins, and the direction of stormwater flow during and upon completion of construction. |
| <input type="checkbox"/> North arrow. | <input type="checkbox"/> Areas of soil disturbance, including all areas affected by clearing, grading, and excavation. |
| <input type="checkbox"/> Existing structures and roads. | <input type="checkbox"/> Locations where stormwater will discharge to surface waters during and upon completion of construction. |
| <input type="checkbox"/> Boundaries and identification of different soil types. | <input type="checkbox"/> Existing unique or valuable vegetation and vegetation to be preserved. |
| <input type="checkbox"/> Areas of potential erosion problems. | <input type="checkbox"/> Cut-and-fill slopes indicating top and bottom of slope catch lines. |
| <input type="checkbox"/> Any on-site and adjacent surface waters, critical areas, buffers, flood plain boundaries, and Shoreline Management boundaries. | <input type="checkbox"/> Total cut-and-fill quantities and the method of disposal for excess material. |
| <input type="checkbox"/> Existing contours and drainage basins and the direction of flow for the different drainage areas. | <input type="checkbox"/> Stockpile; waste storage; and vehicle storage, maintenance, and washdown areas. |
| <input type="checkbox"/> Where feasible, contours extend a minimum of 25 feet beyond property lines and extend sufficiently to depict existing conditions. | |

Temporary and Permanent BMPs

Include the following on site map (where applicable):

- | | |
|---|--|
| <input type="checkbox"/> Locations for temporary and permanent swales, interceptor trenches, or ditches. | <input type="checkbox"/> Details for bypassing off-site runoff around disturbed areas. |
| <input type="checkbox"/> Drainage pipes, ditches, or cut-off trenches associated with erosion and sediment control and stormwater management. | <input type="checkbox"/> Locations of temporary and permanent stormwater treatment and/or flow control best management practices (BMPs). |
| <input type="checkbox"/> Temporary and permanent pipe inverts and minimum slopes and cover. | <input type="checkbox"/> Details for all structural and nonstructural erosion and sediment control (ESC) BMPs (including, but not limited to, silt fences, construction entrances, sedimentation facilities, etc.) |
| <input type="checkbox"/> Grades, dimensions, and direction of flow in all ditches and swales, culverts, and pipes. | <input type="checkbox"/> Details for any construction-phase BMPs or techniques used for Low Impact Development (LID) BMP protection. |
| <input type="checkbox"/> Locations and outlets of any dewatering systems. | |

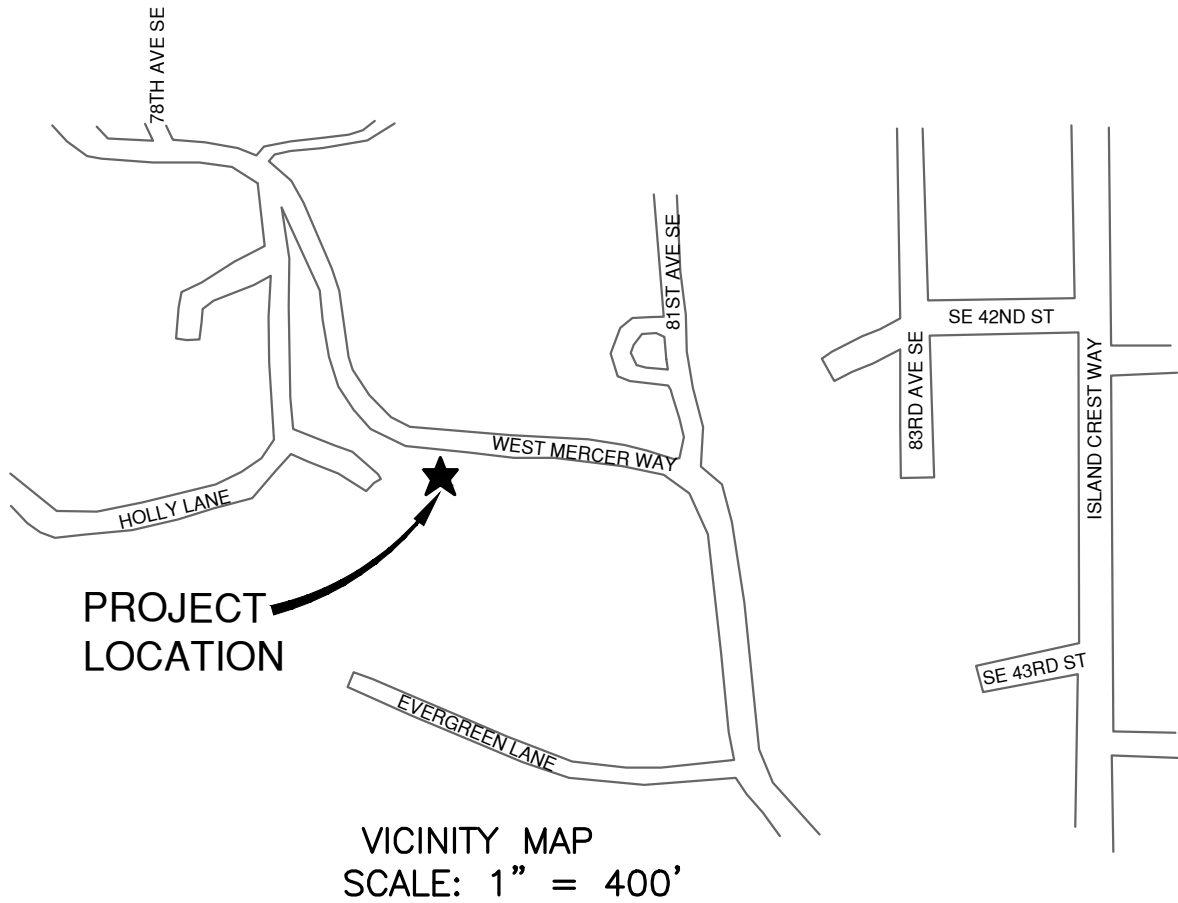

PROJECT ADDRESS

4207 WEST MERCER WAY
MERCER ISLAND, WA 98040

LEGAL DESCRIPTION

THE WEST 82 FEET OF THAT PORTION
OF TRACT 13 IN HARRY WHITE'S PLAT
OF EAST SEATTLE ACRE TRACTS, AS
PER PLAT RECORDED IN VOLUME 3 OF
PLATS, PAGE 36, RECORDS OF KING
COUNTY, LYING SOUTHERLY OF WEST
MERCER WAY RIGHT OF WAY;

TOGETHER WITH THAT PORTION OF THE
EAST 1/2 OF VACATED SECOND STREET
ADJOINING ON THE WEST;

SITUATE IN THE CITY OF MERCER
ISLAND, COUNTY OF KING, STATE OF
WASHINGTON.

PARCEL NUMBER

936570-0163



CALL 48 HOURS BEFORE YOU DIG
1-800-424-5555
OR CALL 8-1-1

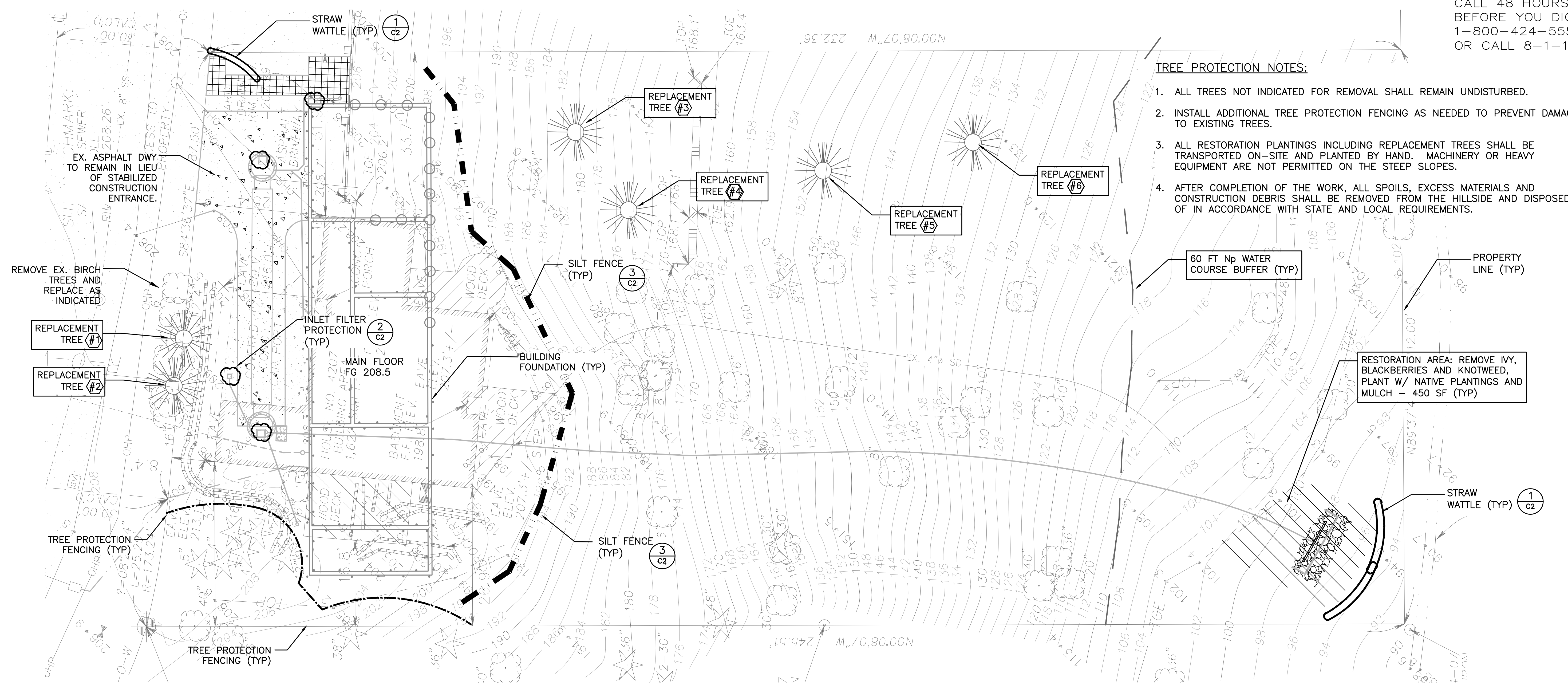

1 C2 STRAW ROLL (WATTLE) DETAIL
SCALE: N.T.S.

2 C2 INLET PROTECTION DETAIL
SCALE: N.T.S.

3 C2 SILT FENCE DETAIL
SCALE: N.T.S.



CITY OF MERCER ISLAND

SECTION B: SMALL PROJECT CONSTRUCTION SWPPP NARRATIVE

Element 1: Preserve Vegetation / Mark Clearing Limits

The goal of this element is to preserve native vegetation and to clearly show the limits of disturbance.

This element **does not** apply to my project because:

The site was cleared as part of clearing activity that is subject to an enforcement action and is re-vegetated. Restoration may be necessary to comply with Critical Area Regulations or NPDES requirements. Buffer Zones-BMP C102 may apply if Critical Areas exist on-site and buffer zones shall be protected.

Other Reason / Additional Comments:

If it **does** apply, describe the steps you will take and select the best management practices (BMPs) you will use:

The perimeter of the area to be cleared shall be marked prior to clearing operation with visible flagging, orange plastic barrier fencing and/or orange silt fencing as shown on the SWPPP site map. The total disturbed area shall be less than 7,000 square feet. Vehicles will only be allowed in the areas to be graded, so no compaction of the undeveloped areas will occur.

Additional Comments:

Check the BMPs you will use:

C101 Preserving Natural Vegetation

C102 Buffer Zones

C103 High Visibility Fence



CITY OF MERCER ISLAND

SECTION B: SMALL PROJECT CONSTRUCTION SWPPP NARRATIVE

Element 2: Construction Access

The goal of this element is to provide a stabilized construction entrance/exit to prevent or reduce or sediment track out.

This element **does not** apply to my project because:

The driveway to the construction area already exists and will be used for construction access. All equipment and vehicles will be restricted to staying on that existing impervious surface.

Other Reason / Additional Comments:

If it **does** apply, describe the steps you will take and select the BMPs you will use:

A stabilized construction entrance will be installed prior to any vehicles entering the site, at the location shown on the SWPPP site map.

Additional Comments:

Check the BMPs you will use:

C105 Stabilized Construction Entrance / Exit

C106 Wheel Wash

C107 Construction Road / Parking Area Stabilization



CITY OF MERCER ISLAND

SECTION B: SMALL PROJECT CONSTRUCTION SWPPP NARRATIVE

Element 3: Control Flow Rates

The goal of this element is to construct retention or detention facilities when necessary to protect properties and waterways downstream of development sites from erosion and turbid discharges.

This element **does not** apply to my project because:

Other Reason / Additional Comments:

If it **does** apply, describe the steps you will take and select the BMPs you will use:

Flow rates will be controlled by using SWPPP Element 4 sediment controls and BMP T5.13 Post-Construction Soil Quality and Depth if necessary.

Additional Comments:



CITY OF MERCER ISLAND

SECTION B: SMALL PROJECT CONSTRUCTION SWPPP NARRATIVE

Element 4: Sediment Control

The goal of this element is to construct sediment control BMPs that minimize sediment discharges from the site.

This element **does not** apply to my project because:

The site has already been stabilized and re-vegetated.

Other Reason / Additional Comments:

If it **does** apply, describe the steps you will take and select the BMPs you will use:

Sediment control BMPs shall be placed at the locations shown on the SWPPP site map

Additional Comments:

Check the BMPs you will use:

C231 Brush Barrier

C233 Silt Fence

C235 Wattles

C232 Gravel Filter Berm

C234 Vegetated Strip



CITY OF MERCER ISLAND

SECTION B: SMALL PROJECT CONSTRUCTION SWPPP NARRATIVE

Element 5: Stabilize Soils

The goal of this element is to stabilize exposed and unworked soils by implementing erosion control BMPs.

This element **does not** apply to my project because:

Other Reason / Additional Comments:

If it **does** apply, describe the steps you will take and select the BMPs you will use:

Exposed soils shall be worked during the week until they have been stabilized. Soil stockpiles will be located within the disturbed area shown on the SWPPP site map. Soil excavated for the foundation will be backfilled against the foundation and graded to drain away from the building. No soils shall remain exposed and unworked for more than 7 days from May 1 to September 30 or more than 2 days from October 1 to April 30. Once the disturbed landscape areas are graded, the grass areas will be amended using BMP T5.13 Post-Construction Soil Quality and Depth. All stockpiles will be covered with plastic or burlap if left unworked.

Additional Comments:

Check the BMPs you will use:

- C120 Temporary & Permanent Seeding
- C122 Nets & Blankets
- C124 Sodding
- C131 Gradient Terraces
- C235 Wattles
- C121 Mulching
- C123 Plastic Covering
- C125 Topsoil / Composting
- C140 Dust Control



CITY OF MERCER ISLAND

SECTION B: SMALL PROJECT CONSTRUCTION SWPPP NARRATIVE

Element 6: Protect Slopes

The goal of this element is to design and construct cut-and-fill slopes in a manner to minimize erosion.

This element **does not** apply to my project because:

No cut slopes over 4 feet high or slopes steeper than 2 feet horizontal to 1 foot vertical, and no fill slopes over 4 feet high will exceed 3 feet horizontal to 1 foot vertical. Therefore, there is no requirement for additional engineered slope protection.

Other Reason / Additional Comments:

If it **does** apply, describe the steps you will take and select the BMPs you will use:

Additional Comments:

Check the BMPs you will use:

- | | | |
|---|---|---|
| <input type="checkbox"/> C120 Temporary & Permanent Seeding | <input type="checkbox"/> C205 Subsurface Drains | <input type="checkbox"/> C207 Check Dams |
| <input type="checkbox"/> C204 Pipe Slope Drains | <input type="checkbox"/> C206 Level Spreader | <input type="checkbox"/> C208 Triangular Silt Dike (Geotextile-Encased Check Dam) |



CITY OF MERCER ISLAND

SECTION B: SMALL PROJECT CONSTRUCTION SWPPP NARRATIVE

Element 7: Protect Permanent Drain Inlets

The goal of this element is to protect storm drain inlets during construction to prevent stormwater runoff from entering the conveyance system without being filtered or treated.

This element **does not** apply to my project because:

- The site has open ditches in the right-of-way or private road right-of-way.
- There are no catch basins on or near the site.
- Other Reason / Additional Comments:

If it **does** apply, describe the steps you will take and select the BMPs you will use:

- Catch basins on the site or immediately off site in the right-of-way are shown on the SWPPP site map. Storm drain inlet protection shall be installed.

Additional Comments:

Check the BMPs you will use:

- C220 Storm Drain Inlet Protection



CITY OF MERCER ISLAND

SECTION B: SMALL PROJECT CONSTRUCTION SWPPP NARRATIVE

Element 8: Stabilize Channels and Outlets

The goal of this element is to design, construct, and stabilize on-site conveyance channels to prevent erosion from entering existing stormwater outfalls and conveyance systems.

This element **does not** apply to my project because:

Construction will occur during the dry weather. No storm drainage channels or ditches shall be constructed either temporary or permanent. A small swale shall be graded to convey yard drainage around the structure using a shallow slope; it shall be seeded after grading and stabilized.

Other Reason / Additional Comments:

If it **does** apply, describe the steps you will take and select the BMPs you will use:

A wattle shall be placed at the end of the swale to prevent erosion at the outlet of the swale.

Additional Comments:

Check the BMPs you will use:

C202 Channel Lining C207 Check Dams C209 Outlet Protection C235 Wattles



CITY OF MERCER ISLAND

SECTION B: SMALL PROJECT CONSTRUCTION SWPPP NARRATIVE

Element 9: Control Pollutants

The goal of this element is to design, install, implement and maintain BMPs to minimize the discharge of pollutants from material storage areas, fuel handling, equipment cleaning, management of waste materials, etc.

This element **does not** apply to my project because:

Other Reason / Additional Comments:

If it **does** apply, describe the steps you will take and select the BMPs you will use:

Any and all pollutants, chemicals, liquid products and other materials that have the potential to pose a threat to human health or the environment will be covered, contained, and protected from vandalism. All such products shall be kept under cover in a secure location on-site. Concrete handling shall follow BMP C151.

Additional Comments:

Check the BMPs you will use:

C151 Concrete Handling

C152 Sawcutting and Surfacing Pollution Prevention

C153 Material Delivery, Storage, and Containment

C154 Concrete Washout Area



CITY OF MERCER ISLAND

SECTION B: SMALL PROJECT CONSTRUCTION SWPPP NARRATIVE

Element 10: Control De-watering

The goal of this element is to handle turbid or contaminated dewatering water separately from stormwater.

This element **does not** apply to my project because:

No dewatering of the site is anticipated.

Other Reason / Additional Comments:

If it **does** apply, describe the steps you will take and select the BMPs you will use:

Additional Comments:

Check the BMPs you will use:

C203 Water Bars

C236 Vegetated Filtration

C206 Level Spreader



CITY OF MERCER ISLAND

SECTION B: SMALL PROJECT CONSTRUCTION SWPPP NARRATIVE

Element 11: Maintain Best Management Practices

The goal of this element is to maintain and repair all temporary and permanent erosion and sediment control BMPs to assure continued performance.

Describe the steps you will take:

- Best Management Practices or BMPs shall be inspected and maintained during construction and removed within 30 days after the City Inspector or Engineer determines that the site is stabilized, provided that they may be removed when they are no longer needed.

Element 12: Manage the Project

The goal of this element is to ensure that the construction SWPPP is properly coordinated and that all BMPs are deployed at the proper time to achieve full compliance with City regulations throughout the project.

If it **does** apply, describe the steps you will take and select the BMPs you will use:

The Construction SWPPP will be implemented at all times. The applicable erosion control BMPs will be implemented in the following sequence:

- 1. Mark clearing limits
- 2. Install stabilized construction entrance
- 3. Install protection for existing drainage systems and permanent drain inlets
- 4. Establish staging areas for storage and handling polluted material and BMPs
- 5. Install sediment control BMPs
- 6. Grade and install stabilization measures for disturbed areas
- 7. Maintain BMPs until site stabilization, at which time they may be removed

Additional Comments:



CITY OF MERCER ISLAND

SECTION B: SMALL PROJECT CONSTRUCTION SWPPP NARRATIVE

Element 13: Protect Low Impact Development BMPs

The goal of this element is to protect on-site stormwater management BMPs (also known as “Low Impact Development BMPs”) from siltation and compaction during construction. On-site stormwater management BMPs used for runoff from roofs and other hard surfaces include: full dispersion, roof downspout full infiltration or dispersion systems, perforated stubout connections, rain gardens, bioretention systems, permeable pavement, sheetflow dispersion, and concentrated flow dispersion. Methods for protecting on-site stormwater management BMPs include sequencing the construction to install these BMPs at the latter part of the construction grading operations, excluding equipment from the BMPs and the associated areas, and using the erosion and sedimentation control BMPs listed below.

Describe the construction sequencing you will use:

Additional Comments:

Select the BMPs you will use:

- | | | |
|---|---|---|
| <input type="checkbox"/> C102 Buffer Zone | <input type="checkbox"/> C103 High Visibility Fence | <input type="checkbox"/> C231 Brush Barrier |
| <input type="checkbox"/> C233 Silt Fence | <input type="checkbox"/> C234 Vegetated Strip | |



CITY OF MERCER ISLAND

SECTION C: INFEASIBILITY CRITERIA

Minimum Requirement #5 (On-Site Stormwater Management)

The following tables summarize infeasibility criteria that can be used to justify not using various on-site stormwater management best management practices (BMPs) for consideration for Minimum Requirement #5. This information is also included under the detailed descriptions of each BMP in the 2014 Stormwater Management Manual for Western Washington (Stormwater Manual), but is provided here in this worksheet for additional clarity and efficiency. Where any inconsistencies or lack of clarity exists, the requirements in the main text of the Stormwater Manual shall be applied. If a project is limited by one or more of the infeasibility criteria specified below, but an applicant is interested in implementing a specific BMP, a functionally equivalent design may be submitted to the City for review and approval. Evaluate the feasibility of the BMPs in priority order based on List #1 or #2 (Small Project Stormwater Requirements Tip Sheet and Stormwater Manual). Select the first BMP that is considered feasible for each surface type. Document the infeasibility (narrative description and rationale) for each BMP that was not selected. Only one infeasibility criterion needs to be selected for a BMP before evaluating the next BMP on the list. Attach additional pages for supporting information if necessary.

Note: If your project discharges directly to Lake Washington (flow control exempt) or a downstream analysis confirms that the downstream system is free of capacity constraints for a minimum of ¼ mile and a maximum of 1 mile, then you do not need to complete this worksheet, but should still refer to the infeasibility criteria when selecting BMPs.

Lawn and Landscaped Areas		
BMP and Applicable Lists	Infeasibility Criteria	Infeasibility Description and Rationale for Each BMP Not Selected
Post-construction Soil Quality and Depth List #1 and #2	<input type="checkbox"/> Siting and design criteria provided in BMP T5.13 (Stormwater Manual Volume V, Section 5.3) cannot be achieved. <input type="checkbox"/> Lawn and landscape area is on till slopes greater than 33 percent.	
Roofs		
BMP and Applicable Lists	Infeasibility Criteria	Infeasibility Description and Rationale for Each BMP Not Selected
Full Dispersion List #1 and #2	<input type="checkbox"/> Site setbacks and design criteria provided in BMP T5.30 (Stormwater Manual Volume V, Section 5.3) cannot be achieved. <input type="checkbox"/> A 65 to 10 ratio of forested or native vegetation area to impervious area cannot be achieved. <input type="checkbox"/> A minimum forested or native vegetation flowpath length of 100 feet (25 feet for sheet flow from a non-native pervious surface) cannot be achieved.	
Downspout Full Infiltration List #1 and #2	<input type="checkbox"/> Evaluation of infiltration is not required per the Infiltration Infeasibility Map due to steep slopes, erosion hazards, or landslide hazards. <input type="checkbox"/> Site setbacks and design criteria provided in BMP T5.10A (Stormwater Manual Volume III, Section 3.1.1) cannot be achieved. <input type="checkbox"/> The lot(s) or site does not have out-wash or loam soils. <input type="checkbox"/> There is not at least 3 feet or more of permeable soil from the proposed final grade to the seasonal high groundwater table or other impermeable layer. <input type="checkbox"/> There is not at least 1 foot or more of permeable soil from the proposed bottom of the infiltration system to the seasonal high groundwater table or other impermeable layer.	



CITY OF MERCER ISLAND

SECTION C: INFEASIBILITY CRITERIA

Roofs (cont.)		
BMP and Applicable Lists	Infeasibility Criteria	Infeasibility Description and Rationale for Each BMP Not Selected
Bioretention or Rain Gardens List #1 (both) and List #2 (bioretention only)	<p><i>Note: Criteria with setback distances are as measured from the bottom edge of the bioretention soil mix.</i></p> <p>Citation of any of the following infeasibility criteria must be based on an evaluation of site-specific conditions and a written recommendation from an appropriate licensed professional (e.g., engineer, geologist, hydrogeologist):</p> <ul style="list-style-type: none"> <input type="checkbox"/> Where professional geotechnical evaluation recommends infiltration not be used due to reasonable concerns about erosion, slope failure, or down-gradient flooding. <input type="checkbox"/> Within an area whose ground water drains into an erosion hazard, or landslide hazard area. <input type="checkbox"/> Where the only area available for siting would threaten the safety or reliability of pre-existing underground utilities, pre-existing underground storage tanks, pre-existing structures, or pre-existing road or parking lot surfaces. <input type="checkbox"/> Where the only area available for siting does not allow for a safe overflow pathway to stormwater drainage system or private storm sewer system. <input type="checkbox"/> Where there is a lack of usable space for bioretention areas at re-development sites, or where there is insufficient space within the existing public right-of-way on public road projects. <input type="checkbox"/> Where infiltrating water would threaten existing below grade basements. <input type="checkbox"/> Where infiltrating water would threaten shoreline structures such as bulkheads. <p>The following criteria can be cited as reasons for infeasibility without further justification (though some require professional services to make the observation):</p> <ul style="list-style-type: none"> <input type="checkbox"/> Evaluation of infiltration is not required per the Infiltration Infeasibility Map due to steep slopes, erosion hazards, or landslide hazards <input type="checkbox"/> Within setback provided for BMP T7.30 (Stormwater Manual Volume V, Section 7.4) <input type="checkbox"/> Where they are not compatible with surrounding drainage system as determined by the city (e.g., project drains to an existing stormwater collection system whose elevation or location precludes connection to a properly functioning bioretention area). 	



CITY OF MERCER ISLAND

SECTION C: INFEASIBILITY CRITERIA

Roofs (cont.)		
BMP and Applicable Lists	Infeasibility Criteria	Infeasibility Description and Rationale for Each BMP Not Selected
Bioretention or Rain Gardens (cont.)	<p>The following criteria can be cited as reasons for infeasibility without further justification (though some require professional services to make the observation):</p> <ul style="list-style-type: none"> <input type="checkbox"/> Where land for bioretention is within an erosion hazard, or landslide hazard area (as defined by MICC 19.07.060). <input type="checkbox"/> Where the site cannot be reasonably designed to locate bioretention areas on slopes less than 8 percent. <input type="checkbox"/> Within 50 feet from the top of slopes that are greater than 20 percent and over 10 feet of vertical relief. <input type="checkbox"/> For properties with known soil or groundwater contamination (typically federal Superfund sites or state cleanup sites under the Model Toxics Control Act [MTCA]): <ul style="list-style-type: none"> • Within 100 feet of an area known to have deep soil contamination. • Where groundwater modeling indicates infiltration will likely increase or change the direction of the migration of pollutants in the groundwater. • Wherever surface soils have been found to be contaminated unless those soils are removed within 10 horizontal feet from the infiltration area. • Any area where these facilities are prohibited by an approved cleanup plan under the state MTCA or Federal Superfund Law, or an environmental covenant under Chapter 64.70 RCW. <input type="checkbox"/> Within 100 feet of a closed or active landfill. <input type="checkbox"/> Within 10 feet of an underground storage tank and connecting underground pipes when the capacity of the tank and pipe system is 1,100 gallons or less. As used in these criteria, an underground storage tank means any tank used to store petroleum products, chemicals, or liquid hazardous wastes of which 10 percent or more of the storage volume (including volume in the connecting piping system) is beneath the ground surface. <input type="checkbox"/> Within 100 feet of an underground storage tank and connecting underground pipes when the capacity of the tank and pipe system is greater than 1,100 gallons. 	



CITY OF MERCER ISLAND

SECTION C: INFEASIBILITY CRITERIA

Roofs (cont.)		
BMP and Applicable Lists	Infeasibility Criteria	Infeasibility Description and Rationale for Each BMP Not Selected
Bioretention or Rain Gardens (cont.)	<p>The following criteria can be cited as reasons for infeasibility without further justification (though some require professional services to make the observation):</p> <ul style="list-style-type: none"> <input type="checkbox"/> Where field testing indicates potential bioretention/rain garden sites have a measured (a.k.a., initial) native soil saturated hydraulic conductivity less than 0.30 inches per hour. A small-scale or large-scale PIT in accordance with Stormwater Manual Volume III, Section 3.3.6 (or an alternative small scale test specified by the City) shall be used to demonstrate infeasibility of bioretention areas. If the measured native soil infiltration rate is less than 0.30 in/hour, bioretention/rain garden BMPs are not required to be evaluated as an option in List #1 or List #2. In these slow draining soils, a bioretention area with an underdrain may be used to treat pollution-generating surfaces to help meet Minimum Requirement #6, Runoff Treatment. If the underdrain is elevated within a base course of gravel, it will also provide some modest flow reduction benefit that will help achieve Minimum Requirement #7. <input type="checkbox"/> Where the minimum vertical separation of 3 feet to the seasonal high groundwater elevation or other impermeable layer would not be achieved below bioretention that would serve a drainage area that exceeds the following thresholds (and cannot reasonably be broken down into amounts smaller than indicated): <ul style="list-style-type: none"> o 5,000 square feet of pollution-generating impervious surface (PGIS) o 10,000 square feet of impervious area o 0.75 acres of lawn and landscape. <input type="checkbox"/> Where the minimum vertical separation of 1 foot to the seasonal high groundwater or other impermeable layer would not be achieved below bioretention that would serve a drainage area less than the above thresholds. <input type="checkbox"/> Within 100 feet of a drinking water well, or a spring used for drinking water supply. <input type="checkbox"/> Within 10 feet of small on-site sewage disposal drainfield, including reserve areas, and grey water reuse systems. For setbacks from a "large on-site sewage disposal system," see Chapter 246-272B WAC. 	



CITY OF MERCER ISLAND

SECTION C: INFEASIBILITY CRITERIA

Roofs (cont.)		
BMP and Applicable Lists	Infeasibility Criteria	Infeasibility Description and Rationale for Each BMP Not Selected
Downspout Dispersion Systems List #1 and #2	<ul style="list-style-type: none"> <input type="checkbox"/> Site setbacks and design criteria provided in BMP T5.10B (Stormwater Manual Volume III, Section 3.1.2) cannot be achieved. <input type="checkbox"/> For splash blocks, a vegetated flowpath at least 50 feet in length from the downspout to the downstream property line, structure, stream, wetland, slope over 15 percent, or other impervious surface is not feasible. <input type="checkbox"/> For trenches, a vegetated flowpath of at least 25 feet in between the outlet of the trench and any property line, structure, stream, wetland, or impervious surface is not feasible. A vegetated flowpath of at least 50 feet between the outlet of the trench and any slope steeper than 15 percent is not feasible. 	
Perforated Stub-Out Connections List #1 and #2	<ul style="list-style-type: none"> <input type="checkbox"/> Evaluation of infiltration is not required per the Infiltration Infeasibility Map due to steep slopes, erosion hazards, or landslide hazards <input type="checkbox"/> For sites with septic systems, the only location available for the perforated portion of the pipe is located up-gradient of the drainfield primary and reserve areas. This requirement can be waived if site topography will clearly prohibit flows from intersecting the drainfield or where site conditions (soil permeability, distance between systems, etc.) indicate that this is unnecessary. <input type="checkbox"/> Site setbacks and design criteria provided in BMP T5.10C (Stormwater Manual Volume III, Section 3.1.3) cannot be achieved. <input type="checkbox"/> There is not at least 1 foot of permeable soil from the proposed bottom (final grade) of the perforated stub-out connection trench to the highest estimated groundwater table or other impermeable layer. <input type="checkbox"/> The only location available for the perforated stub-out connection is under impervious or heavily compacted soils. 	
On-site Detention List #1 and #2	<ul style="list-style-type: none"> <input type="checkbox"/> Project discharges directly to Lake Washington. <input type="checkbox"/> Findings from a 1/4 mile downstream analysis confirm that the downstream system is free of capacity constraints. <input type="checkbox"/> Site setbacks and design criteria provided in the Stormwater Manual (Volume III, Section 3.2.2) cannot be achieved. 	



CITY OF MERCER ISLAND

SECTION C: INFEASIBILITY CRITERIA

Other Hard Surfaces		
BMP and Applicable Lists	Infeasibility Criteria	Infeasibility Description and Rationale for Each BMP Not Selected
Full Dispersion List #1 and #2	<ul style="list-style-type: none"> <input type="checkbox"/> Site setbacks and design criteria provided in BMP T5.30 (Stormwater Manual Volume V, Section 5.3) cannot be achieved. <input type="checkbox"/> A 65 to 10 ratio of forested or native vegetation area to impervious area cannot be achieved. <input type="checkbox"/> A minimum forested or native vegetation flowpath length of 100 feet (25 feet for sheet flow from a non-native pervious surface) cannot be achieved. 	
Permeable Pavement List #1 and #2	<p>Citation of any of the following infeasibility criteria must be based on an evaluation of site-specific conditions and a written recommendation from an appropriate licensed professional (e.g., engineer, geologist, hydrogeologist):</p> <ul style="list-style-type: none"> <input type="checkbox"/> Where professional geotechnical evaluation recommends infiltration not be used due to reasonable concerns about erosion, slope failure, or downgradient flooding. <input type="checkbox"/> Within an area whose ground water drains into an erosion hazard, or landslide hazard area. <input type="checkbox"/> Where infiltrating and ponded water below the new permeable pavement area would compromise adjacent impervious pavements. <input type="checkbox"/> Where infiltrating water below a new permeable pavement area would threaten existing below grade basements. <input type="checkbox"/> Where infiltrating water would threaten shoreline structures such as bulkheads. <input type="checkbox"/> Down slope of steep, erosion prone areas that are likely to deliver sediment. <input type="checkbox"/> Where fill soils are used that can become unstable when saturated. <input type="checkbox"/> Excessively steep slopes where water within the aggregate base layer or at the subgrade surface cannot be controlled by detention structures and may cause erosion and structural failure, or where surface runoff velocities may preclude adequate infiltration at the pavement surface. <input type="checkbox"/> Where permeable pavements cannot provide sufficient strength to support heavy loads at industrial facilities such as ports. <input type="checkbox"/> Where installation of permeable pavement would threaten the safety or reliability of pre-existing underground utilities, pre-existing underground storage tanks, or pre-existing road subgrades. 	



CITY OF MERCER ISLAND

SECTION C: INFEASIBILITY CRITERIA

Other Hard Surfaces (cont.)		
BMP and Applicable Lists	Infeasibility Criteria	Infeasibility Description and Rationale for Each BMP Not Selected
Permeable Pavement (cont.)	<p>The following criteria can be cited as reasons for infeasibility without further justification (though some require professional services to make the observation):</p> <ul style="list-style-type: none"> <input type="checkbox"/> Evaluation of infiltration is not required per the Infiltration Infeasibility Map due to steep slopes, erosion hazards, or landslide hazards <input type="checkbox"/> Within an area designated as an erosion hazard, or landslide hazard. <input type="checkbox"/> Within 50 feet from the top of slopes that are greater than 20 percent. <input type="checkbox"/> For properties with known soil or groundwater contamination (typically federal Superfund sites or state cleanup sites under MTCA): <ul style="list-style-type: none"> • Within 100 feet of an area known to have deep soil contamination. • Where groundwater modeling indicates infiltration will likely increase or change the direction of the migration of pollutants in the groundwater. • Wherever surface soils have been found to be contaminated unless those soils are removed within 10 horizontal feet from the infiltration area. • Any area where these facilities are prohibited by an approved cleanup plan under the state MTCA or Federal Superfund Law, or an environmental covenant under Chapter 64.70 RCW. <input type="checkbox"/> Within 100 feet of a closed or active landfill. <input type="checkbox"/> Within 100 feet of a drinking water well, or a spring used for drinking water supply, if the pavement is a pollution-generating surface. <input type="checkbox"/> Within 10 feet of a small on-site sewage disposal drainfield, including reserve areas, and grey water reuse systems. For setbacks from a “large on-site sewage disposal system,” see Chapter 246-272B WAC. <input type="checkbox"/> Within 10 feet of any underground storage tank and connecting underground pipes, regardless of tank size. As used in these criteria, an underground storage tank means any tank used to store petroleum products, chemicals, or liquid hazardous wastes of which 10 percent or more of the storage volume (including volume in the connecting piping system) is beneath the ground surface. <input type="checkbox"/> At multi-level parking garages, and over culverts and bridges. <input type="checkbox"/> Where the site design cannot avoid putting pavement in areas likely to have long-term excessive sediment deposition after construction (e.g., construction and landscaping material yards). 	



CITY OF MERCER ISLAND

SECTION C: INFEASIBILITY CRITERIA

Other Hard Surfaces (cont.)		
BMP and Applicable Lists	Infeasibility Criteria	Infeasibility Description and Rationale for Each BMP Not Selected
Permeable Pavement (cont.)	<p>The following criteria can be cited as reasons for infeasibility without further justification (though some require professional services to make the observation):</p> <ul style="list-style-type: none"> <input type="checkbox"/> Where the site cannot reasonably be designed to have: <ul style="list-style-type: none"> • Porous asphalt surface < 5% slope • Pervious concrete surface < 10% slope • Permeable interlocking concrete pavement surface < 12% slope • Grid systems < 6-12% slope (check with manufacturer and local supplier to confirm maximum slope) <input type="checkbox"/> Where the subgrade soils below a pollution-generating permeable pavement (e.g., road or parking lot) do not meet the soil suitability criteria for providing treatment. See soil suitability criteria for treatment in the Stormwater Manual Volume III, Section 3.3.7. Note: In these instances, the city may approve installation of a 6 inch sand filter layer meeting city specifications for treatment as a condition of construction. <input type="checkbox"/> Where underlying soils are unsuitable for supporting traffic loads when saturated. Soils meeting a California Bearing Ratio of 5 percent are considered suitable for residential access roads. <input type="checkbox"/> Where replacing existing impervious surfaces unless the existing surface is a non-pollution generating surface over an outwash soil with a saturated hydraulic conductivity of 4 inches per hour or greater. <input type="checkbox"/> Where appropriate field testing indicates soils have a measured (a.k.a., initial) subgrade soil saturated hydraulic conductivity less than 0.3 inches per hour. Only small-scale PIT or large-scale PIT methods in accordance with Stormwater Manual Volume III, Section 3.3.6 (or an alternative small scale test specified by the City) shall be used to evaluate infeasibility of permeable pavement areas. (Note: In these instances, unless other infeasibility restrictions apply, roads and parking lots may be built with an underdrain, preferably elevated within the base course, if flow control benefits are desired.) <input type="checkbox"/> Roads that receive more than very low traffic volumes, and areas having more than very low truck traffic. Roads with a projected average daily traffic volume of 400 vehicles or less are very low volume roads (AASHTO 2001) (U.S. Department of Transportation, 2013). Areas with very low truck traffic volumes are roads and other areas not subject to through truck traffic but may receive up to weekly use by utility trucks (e.g., garbage, recycling), daily school bus use, and multiple daily use by pick-up trucks, mail/parcel delivery trucks, and maintenance vehicles. (Note: This infeasibility criterion does not extend to sidewalks and other non-traffic bearing surfaces associated with the collector or arterial). 	



CITY OF MERCER ISLAND

SECTION C: INFEASIBILITY CRITERIA

Other Hard Surfaces (cont.)		
BMP and Applicable Lists	Infeasibility Criteria	Infeasibility Description and Rationale for Each BMP Not Selected
Permeable Pavement (cont.)	<p>The following criteria can be cited as reasons for infeasibility without further justification (though some require professional services to make the observation):</p> <ul style="list-style-type: none"> <input type="checkbox"/> At sites defined as “high-use sites” (refer to the Glossary in the Stormwater Manual Volume I). <input type="checkbox"/> In areas with “industrial activity” as identified in 40 CFR 122.26(b)(14). <input type="checkbox"/> Where the risk of concentrated pollutant spills is more likely such as gas stations, truck stops, and industrial chemical storage sites. <input type="checkbox"/> Where routine, heavy applications of sand occur in frequent snow zones to maintain traction during weeks of snow and ice accumulation. <input type="checkbox"/> Where the seasonal high groundwater or an underlying impermeable/ low permeable layer would create saturated conditions within 1 foot of the bottom of the lowest gravel base course. 	
Bioretention or Rain Gardens List #1 (both) and List #2 (bioretention only)	<p><i>Note: Criteria with setback distances are as measured from the bottom edge of the bioretention soil mix.</i></p> <p>Citation of any of the following infeasibility criteria must be based on an evaluation of site-specific conditions and a written recommendation from an appropriate licensed professional (e.g., engineer, geologist, hydrogeologist):</p> <ul style="list-style-type: none"> <input type="checkbox"/> Where professional geotechnical evaluation recommends infiltration not be used due to reasonable concerns about erosion, slope failure, or down-gradient flooding. <input type="checkbox"/> Within an area whose ground water drains into an erosion hazard, or landslide hazard area. <input type="checkbox"/> Where the only area available for siting would threaten the safety or reliability of pre-existing underground utilities, pre-existing underground storage tanks, pre-existing structures, or pre-existing road or parking lot surfaces. <input type="checkbox"/> Where the only area available for siting does not allow for a safe overflow pathway to stormwater drainage system or private storm sewer system. <input type="checkbox"/> Where there is a lack of usable space for bioretention areas at re-development sites, or where there is insufficient space within the existing public right-of-way on public road projects. <input type="checkbox"/> Where infiltrating water would threaten existing below grade basements. <input type="checkbox"/> Where infiltrating water would threaten shoreline structures such as bulkheads. 	



CITY OF MERCER ISLAND

SECTION C: INFEASIBILITY CRITERIA

Other Hard Surfaces (cont.)		
BMP and Applicable Lists	Infeasibility Criteria	Infeasibility Description and Rationale for Each BMP Not Selected
Bioretention or Rain Gardens (cont.)	<p>The following criteria can be cited as reasons for infeasibility without further justification (though some require professional services to make the observation):</p> <ul style="list-style-type: none"> <input type="checkbox"/> Where evaluation of infiltration is not required per the Infiltration Infeasibility Map due to steep slopes, erosion hazards, or landslide hazards. <input type="checkbox"/> Within setback provided for BMP T7.30 (Stormwater Manual Volume V, Section 7.4) <input type="checkbox"/> Where they are not compatible with surrounding drainage system as determined by the city (e.g., project drains to an existing stormwater collection system whose elevation or location precludes connection to a properly functioning bioretention area). <input type="checkbox"/> Where land for bioretention is within an erosion hazard, or landslide hazard area (as defined by MICC 19.07.060). <input type="checkbox"/> Where the site cannot be reasonably designed to locate bioretention areas on slopes less than 8 percent. <input type="checkbox"/> Within 50 feet from the top of slopes that are greater than 20 percent and over 10 feet of vertical relief. <input type="checkbox"/> For properties with known soil or groundwater contamination (typically federal Superfund sites or state cleanup sites under the Model Toxics Control Act [MTCA]): <ul style="list-style-type: none"> • Within 100 feet of an area known to have deep soil contamination. • Where groundwater modeling indicates infiltration will likely increase or change the direction of the migration of pollutants in the groundwater. • Wherever surface soils have been found to be contaminated unless those soils are removed within 10 horizontal feet from the infiltration area. • Any area where these facilities are prohibited by an approved cleanup plan under the state MTCA or Federal Superfund Law, or an environmental covenant under Chapter 64.70 RCW. <input type="checkbox"/> Within 100 feet of a closed or active landfill. <input type="checkbox"/> Within 10 feet of an underground storage tank and connecting underground pipes when the capacity of the tank and pipe system is 1,100 gallons or less. As used in these criteria, an underground storage tank means any tank used to store petroleum products, chemicals, or liquid hazardous wastes of which 10 percent or more of the storage volume (including volume in the connecting piping system) is beneath the ground surface. 	



CITY OF MERCER ISLAND

SECTION C: INFEASIBILITY CRITERIA

Other Hard Surfaces (cont.)		
BMP and Applicable Lists	Infeasibility Criteria	Infeasibility Description and Rationale for Each BMP Not Selected
Bioretention or Rain Gardens (cont.)	<p>The following criteria can be cited as reasons for infeasibility without further justification (though some require professional services to make the observation):</p> <ul style="list-style-type: none"> <input type="checkbox"/> Within 100 feet of an underground storage tank and connecting underground pipes when the capacity of the tank and pipe system is greater than 1,100 gallons. <input type="checkbox"/> Where field testing indicates potential bioretention/rain garden sites have a measured (a.k.a., initial) native soil saturated hydraulic conductivity less than 0.30 inches per hour. A small-scale or large-scale PIT in accordance with Stormwater Manual Volume III, Section 3.3.6 (or an alternative small scale test specified by the City) shall be used to demonstrate infeasibility of bioretention areas. If the measured native soil infiltration rate is less than 0.30 in/hour, bioretention/rain garden BMPs are not required to be evaluated as an option in List #1 or List #2. In these slow draining soils, a bioretention area with an underdrain may be used to treat pollution-generating surfaces to help meet Minimum Requirement #6, Runoff Treatment. If the underdrain is elevated within a base course of gravel, it will also provide some modest flow reduction benefit that will help achieve Minimum Requirement #7. <input type="checkbox"/> Where the minimum vertical separation of 3 feet to the seasonal high groundwater elevation or other impermeable layer would not be achieved below bioretention that would serve a drainage area that exceeds the following thresholds (and cannot reasonably be broken down into amounts smaller than indicated): <ul style="list-style-type: none"> o 5,000 square feet of pollution-generating impervious surface (PGIS) o 10,000 square feet of impervious area o 0.75 acres of lawn and landscape. <input type="checkbox"/> Where the minimum vertical separation of 1 foot to the seasonal high groundwater or other impermeable layer would not be achieved below bioretention that would serve a drainage area less than the above thresholds <input type="checkbox"/> Within 100 feet of a drinking water well, or a spring used for drinking water supply. <input type="checkbox"/> Within 10 feet of small on-site sewage disposal drainfield, including reserve areas, and grey water reuse systems. For setbacks from a "large on-site sewage disposal system," see Chapter 246-272B WAC. 	



CITY OF MERCER ISLAND

SECTION C: INFEASIBILITY CRITERIA

Other Hard Surfaces (cont.)		
BMP and Applicable Lists	Infeasibility Criteria	Infeasibility Description and Rationale for Each BMP Not Selected
Sheet Flow Dispersion List #1 and #2	<ul style="list-style-type: none"> <input type="checkbox"/> Site setbacks and design criteria provided in BMP T5.12 (Stormwater Manual Volume V, Section 5.3) cannot be achieved. <input type="checkbox"/> Positive drainage for sheet flow runoff cannot be achieved. <input type="checkbox"/> Area to be dispersed (e.g., driveway, patio) cannot be graded to have less than a 15 percent slope. <input type="checkbox"/> For flat to moderately sloped areas, at least a 10 foot-wide vegetation buffer for dispersion of the adjacent 20 feet of contributing surface cannot be achieved. For variably sloped areas, at least a 25 foot vegetated flowpath between berms cannot be achieved. 	
Concentrated Flow Dispersion List #1 and #2	<ul style="list-style-type: none"> <input type="checkbox"/> Site setbacks and design criteria provided in BMP T5.11 (Stormwater Manual Volume V, Section 5.3) cannot be achieved. <input type="checkbox"/> A minimum 3 foot length of rock pad and 50 foot flowpath OR a dispersion trench and 25 foot flowpath for every 700 square feet of drainage area followed with applicable setbacks cannot be achieved. <input type="checkbox"/> More than 700 square feet drainage area drains to any dispersion device. 	
On-site Detention List #1 and #2	<ul style="list-style-type: none"> <input type="checkbox"/> Project discharges directly to Lake Washington. <input type="checkbox"/> Findings from a 1/4 mile downstream analysis confirm that the downstream system is free of capacity constraints. <input type="checkbox"/> Site setbacks and design criteria provided in the Stormwater Manual (Volume III, Section 3.2.2) cannot be achieved. 	



CITY OF MERCER ISLAND

SECTION D: POST-CONSTRUCTION SOIL MANAGEMENT

Attachments Required *(Check off required items that are attached)*

<input type="checkbox"/>	Site Plan showing, to scale: <ul style="list-style-type: none"> <input type="checkbox"/> Areas of undisturbed native vegetation (no amendment required) <input type="checkbox"/> New planting beds (amendment required) <input type="checkbox"/> New turf areas (amendment required) <input type="checkbox"/> Type of soil improvement proposed for each area
<input type="checkbox"/>	Soil test results (required if proposing custom amendment rates)
<input type="checkbox"/>	Product test results for proposed amendments

Total Amendment / Topsoil / Mulch for All Areas

Calculate the quantities needed for the entire site based on all of the areas identified on the Site Plan and the calculations on the following page(s):

Product	Total Quantity (CY)	Test Results
Product #1: _____	_____ CY	_____ % organic matter _____ C:N ratio "Stable"? yes <input type="checkbox"/> no <input type="checkbox"/>
Product #2: _____	_____ CY	_____ % organic matter _____ C:N ratio "Stable"? yes <input type="checkbox"/> no <input type="checkbox"/>
Product #3: _____	_____ CY	_____ % organic matter _____ C:N ratio "Stable"? yes <input type="checkbox"/> no <input type="checkbox"/>

CY = cubic yards, C:N = Carbon:Nitrogen



CITY OF MERCER ISLAND

SECTION D: POST-CONSTRUCTION SOIL MANAGEMENT

Amendment / Topsoil / Mulch by Area

For each identified area on your Site Plan, provide the following information: (Use additional sheets if necessary)

Area # 1 (should match identified Area # on Site Plan)

Planting type: Turf Undisturbed native vegetation
 Planting Beds Other: _____

Pre-Approved Amendment Method

<input type="checkbox"/> Amend with compost	Turf: _____ SF x 5.4 CY ÷ 1,000 SF = _____ CY Planting beds: <u>2640</u> SF x 9.3 CY ÷ 1,000 SF = <u>24.6</u> CY Total Quantity = _____ CY Scarification depth: 8 inches	Product: <u>Compost</u>
<input type="checkbox"/> Stockpile and amend	Turf: _____ SF x 5.4 CY ÷ 1,000 SF = _____ CY Planting beds: _____ SF x 9.3 CY ÷ 1,000 SF = _____ CY Total Quantity = _____ CY Scarification depth: 8 inches	Product: _____
<input type="checkbox"/> Topsoil import	Turf: _____ SF x 18.6 CY ÷ 1,000 SF = _____ CY Planting beds: _____ SF x 18.6 CY ÷ 1,000 SF = _____ CY Total Quantity = _____ CY Scarification depth: 6 inches	Product: _____

Custom Amendment

<input type="checkbox"/> Amend with compost	Attach information on bulk density, percent organic matter, moisture content, C:N ratio, and heavy metals analysis to support custom amendment rate and scarification depth. Total Quantity = _____ CY Scarification depth: _____ inches	Product: _____
<input type="checkbox"/> Stockpile and amend	Attach information on bulk density, percent organic matter, moisture content, C:N ratio, and heavy metals analysis to support custom amendment rate and scarification depth. Total Quantity = _____ CY Scarification depth: _____ inches	Product: _____

Mulch

<input type="checkbox"/> Amend with compost	Planting beds: _____ SF x 12.4 CY ÷ 1,000 SF = _____ CY Total Quantity = _____ CY	Product: _____
<input checked="" type="checkbox"/> Stockpile and amend	Planting beds: <u>2640</u> SF x 12.4 CY ÷ 1,000 SF = <u>32.7</u> CY Total Quantity = <u>32.7</u> CY	Product: <u>Arborist's Mulch</u>
<input type="checkbox"/> Topsoil import	Planting beds: _____ SF x 12.4 CY ÷ 1,000 SF = _____ CY Total Quantity = _____ CY	Product: _____

CY = cubic yards, C:N = Carbon:Nitrogen



CITY OF MERCER ISLAND

SECTION D: POST-CONSTRUCTION SOIL MANAGEMENT

Amendment / Topsoil / Mulch by Area

For each identified area on your Site Plan, provide the following information: (Use additional sheets if necessary)

Area # _____ (should match identified Area # on Site Plan)

Planting type: Turf Undisturbed native vegetation
 Planting Beds Other: _____

Pre-Approved Amendment Method

<input type="checkbox"/> Amend with compost	Turf: _____ SF x 5.4 CY ÷ 1,000 SF = _____ CY Planting beds: _____ SF x 9.3 CY ÷ 1,000 SF = _____ CY Total Quantity = _____ CY Scarification depth: 8 inches	Product: _____
<input type="checkbox"/> Stockpile and amend	Turf: _____ SF x 5.4 CY ÷ 1,000 SF = _____ CY Planting beds: _____ SF x 9.3 CY ÷ 1,000 SF = _____ CY Total Quantity = _____ CY Scarification depth: 8 inches	Product: _____
<input type="checkbox"/> Topsoil import	Turf: _____ SF x 18.6 CY ÷ 1,000 SF = _____ CY Planting beds: _____ SF x 18.6 CY ÷ 1,000 SF = _____ CY Total Quantity = _____ CY Scarification depth: 6 inches	Product: _____

Custom Amendment

<input type="checkbox"/> Amend with compost	Attach information on bulk density, percent organic matter, moisture content, C:N ratio, and heavy metals analysis to support custom amendment rate and scarification depth. Total Quantity = _____ CY Scarification depth: _____ inches	Product: _____
<input type="checkbox"/> Stockpile and amend	Attach information on bulk density, percent organic matter, moisture content, C:N ratio, and heavy metals analysis to support custom amendment rate and scarification depth. Total Quantity = _____ CY Scarification depth: _____ inches	Product: _____

Mulch

<input type="checkbox"/> Amend with compost	Planting beds: _____ SF x 12.4 CY ÷ 1,000 SF = _____ CY Total Quantity = _____ CY	Product: _____
<input type="checkbox"/> Stockpile and amend	Planting beds: _____ SF x 12.4 CY ÷ 1,000 SF = _____ CY Total Quantity = _____ CY	Product: _____
<input type="checkbox"/> Topsoil import	Planting beds: _____ SF x 12.4 CY ÷ 1,000 SF = _____ CY Total Quantity = _____ CY	Product: _____

CY = cubic yards, C:N = Carbon:Nitrogen

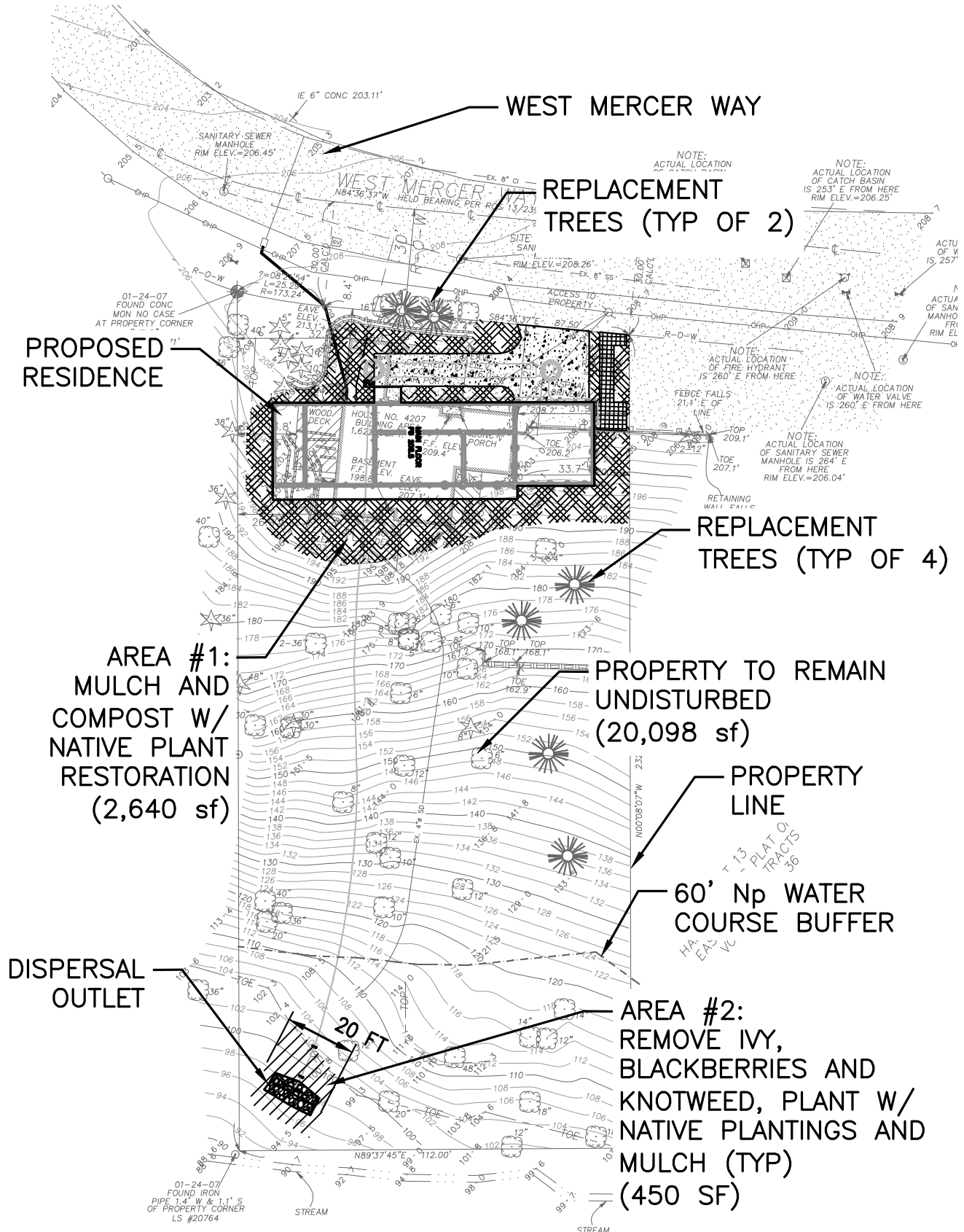

PROPOSED RESIDENCE

WEST MERCER WAY

REPLACEMENT TREES (TYP OF 2)

REPLACEMENT TREES (TYP OF 4)

**AREA #1:
MULCH AND
COMPOST W/
NATIVE PLANT
RESTORATION
(2,640 sf)**

**PROPERTY TO REMAIN
UNDISTURBED
(20,098 sf)**

PROPERTY LINE

**60' Np WATER
COURSE BUFFER**

**DISPERSAL
OUTLET**

**AREA #2:
REMOVE IVY,
BLACKBERRIES AND
KNOTWEED, PLANT W/
NATIVE PLANTINGS AND
MULCH (TYP)
(450 SF)**

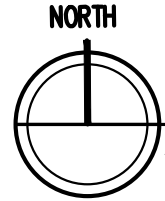

SOIL RESTORATION PLAN
4207 West Mercer Way

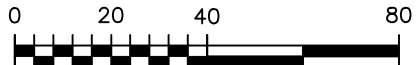

SCALE: 1" = 40'

CALL 48 HOURS BEFORE YOU DIG
1-800-424-5555
OR CALL 8-1-1

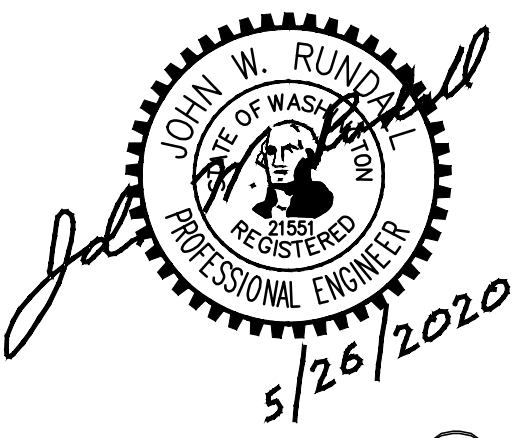

VANEY / SHINDE
New Residence
4207 West Mercer Way
Mercer Island, WA 98040

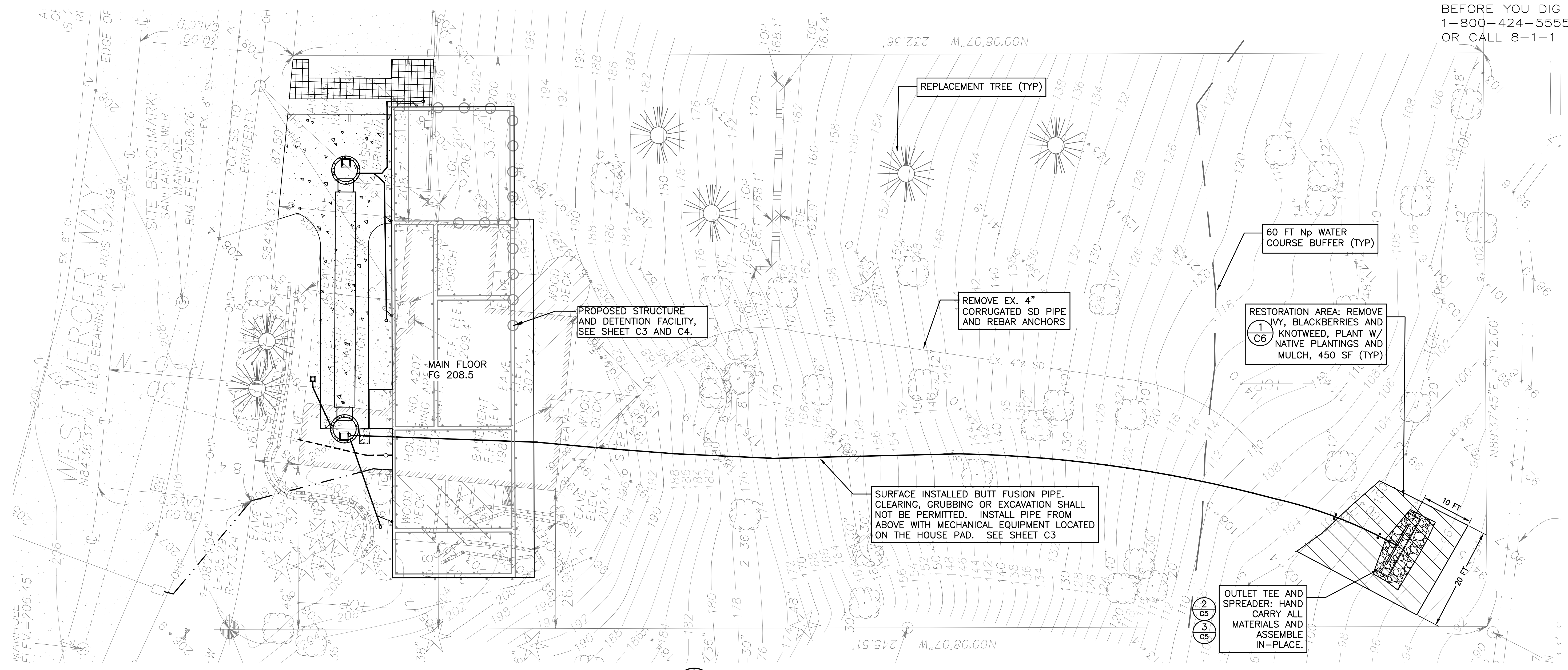

RESTORATION PLAN
SCALE: 1" = 10'

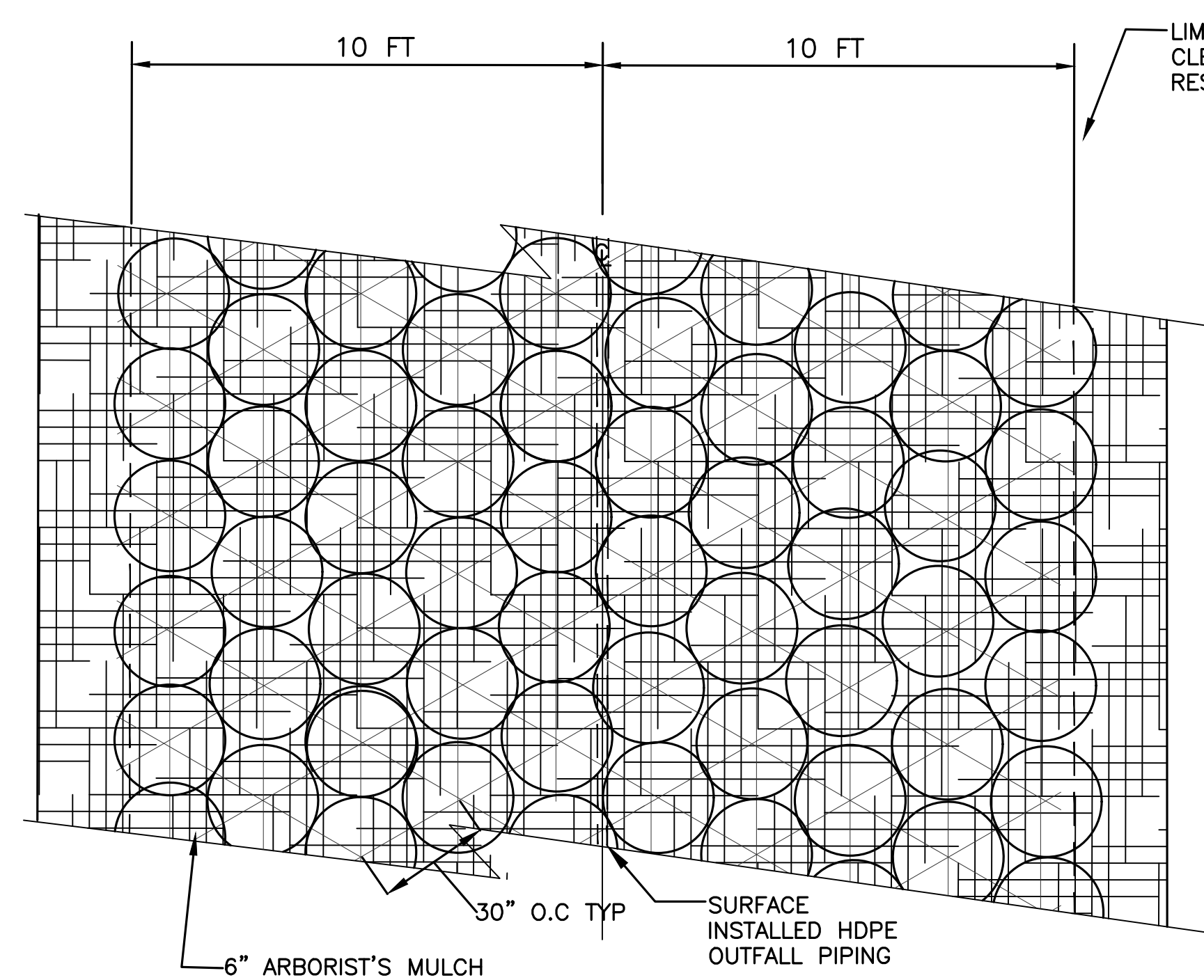
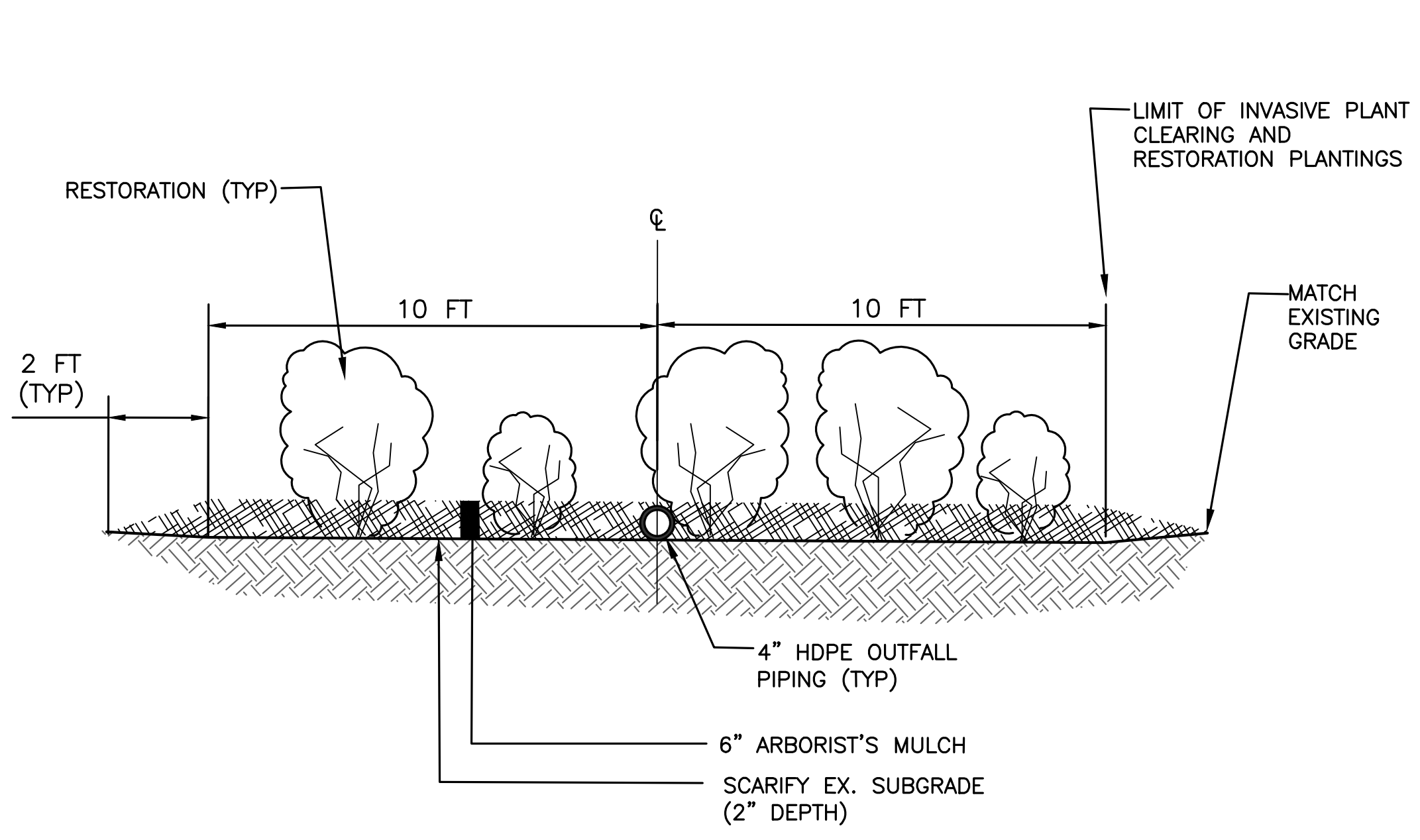

- SOIL AND PLANTING NOTES:**
- EXISTING INVASIVE WEEDS (PARTICULARLY HIMALAYAN BLACKBERRIES AND JAPANESE KNOTWEED) SHALL BE REMOVED IN THEIR ENTIRETY INCLUDING ROOTS (CORMS AND RHIZOMES).
 - THE INVASIVE PLANT MATERIAL SHALL BE REMOVED FROM THE SITE AND DISPOSED OF IN ACCORDANCE WITH KING COUNTY NOXIOUS WEED CONTROL REQUIREMENTS.
 - PRIOR TO PLANTING, THE SOIL SHALL BE SCARIFIED AND COVERED WITH A MINIMUM OF 6" OF ARBORISTS MULCH.
 - PLANTINGS SHALL BE MINIMUM 1 GALLON.
 - PLANTS SHALL BE SPACED AT 30" O.C., TRIANGULAR SPACING.
 - PLANTINGS SHALL BE A RANDOM DISTRIBUTION OF A MIX OF THE PLANTS INDICATED ON THE PLANT LIST.

PLANT LIST:

PLANT	COMMON NAME	QUANTITY
1. CORNUS STOLONIFERA	REDTIG DOGWOOD	12
2. LONICERA INVOLUCRATA	TWINBERRY	12
3. PHILADELPHUS LEWISII	MOCK-ORANGE	12
4. RIBES SANGUINEUM	RED FLOWERING CURRANT	12
5. ROSA NUTKANA	NOOTKA ROSE	12
6. RUBUS PARVIFLORA	THIMBLEBERRY	12
7. RUBUS SPECTABILIS	SALMONBERRY	12

- LEGEND**
- AREA DRAIN
 - CATCH BASIN, TYPE 2-54"
 - CLEAN OUT
 - DOWNSPOUT CONNECTION
 - - - FOUNDATION DRAIN
 - FOUNDATION DRAIN CLEANOUT
 - PROPANE
 - - - SANITARY SIDE SEWER
 - STORM DRAIN
 - - - WATER SERVICE

1 WATER COURSE BUFFER RESTORATION PLANTING PLAN
C6 NTS

Date: 5/21/20 Permit Set

Scale: 1" = 10'
Sheet: 6 of 6

WATERCOURSE BUFFER RESTORATION PLAN

C6



CITY OF MERCER ISLAND

SECTION E: SIGNATURE PAGE

Project Engineer's Certification for Section B

For Stormwater Site Plans with engineered elements, the Construction SWPPP is stamped by a professional engineer licensed in the State of Washington in civil engineering.

If required, attach a page with the project engineer's seal with the following statement:

*"I hereby state that this Construction Stormwater Pollution Prevention Plan for _____
(name of project)
has been prepared by me or under my supervision and meets the standard of care and expertise which is usual and customary in this community for professional engineers. I understand that the City of Mercer Island does not and will not assume liability for the sufficiency, suitability, or performance of Construction SWPPP BMPs prepared by me."*

Applicant Signature for Full Stormwater Package (Sections A through D)

I have read and completed the Stormwater Submittal Package and know the information provided to be true and correct.

Print Applicant Name: _____

Applicant Signature: _____ Date _____

SMALL PROJECT STORMWATER REPORT

CIVIL ENGINEER

The Civil Engineer's seal and signature affixed hereon indicates this Engineer's review and participation in the preparation of this Checklist as indicated.

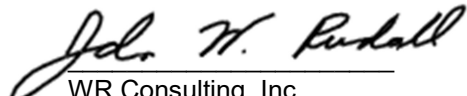
WR Consulting, Inc.

